

LKL-P021R-XX



Product Description

LEKOLED LKL-P02 IR high power led series covers the range of wavelength 740-745nm, 850nm and 930-940nm. Unique and perfect raw materials combination and strict reliability tests (eg: temperature shock test; high temperature aging test etc) ensures its stability and excellent performance in heat conduction and light output. It's been widely applied to sensor, monitor, surveillance etc.

Features

- Designed for high current operation
- Low thermal resistance:12°C/W
- SMT solder ability
- RoHS compliant
- > 50000Hrs

Application

- Sensor;
- Monitor, Surveillance;

Table of Content

Characteristics.....	2
Coding Rules.....	2
Specifications.....	3
Spectral Features.....	4
Electrical Features	4
Typical Spatial Distribution.....	5
Dimensions.....	5
Reflow Soldering Features.....	6
Reliability Tests	7
Packaging	8
Packaging	9
Notes	10



Characteristics

Characteristics	Unit	Min	Typical	Max
Dimension L*W	mm		14.5*8.05	
Diameter of Luminous Area Φ	mm		5.5	
Beam Angle θ	deg.		120	
Wavelength WL	nm	740		940
Power Dissipation PD	W		1	3
Operating Temperature Top	°C	-40		+60
Storage Temperature Tst	°C	-40		+85
Testing Point Tc	°C			60
Junction Temperature Tj	°C			115
Reverse Current (Vr=5V) Ir	uA			10
Thermal Resistance Rj-c	°C/W		12	
ESD (HBM)	V			2000
Reflow Soldering (Lead-Free) ST	°C			180

Coding Rules

Model	LKL	P	02	XX	X	X	X	X
Code	LKL	P	Type	Emitting Color	Chip Size	Chip QTY	Beam Angle	Power
Meaning	LEKOLED	High Power Series	High temperature PC lens	IR: 850nm IR2: 740-745nm IR4: 930-940nm	4: 45mill	1: 1EA	0: 120°	1: 1W

Specifications (Tc = 25°C)

Color	Voltage (V)	Current (mA)	Wavelength (nm)	Radiation Flux (mW)	Part Number
IR	1.7-1.9	400	740-745	80	LKL-P02IR2101
	1.5-1.7	400	850	70	LKL-P02IR4101
	1.5-1.7	400	940	70	LKL-P02IR44101

Notes:

Above charts include the most regular specs for IR leds for reference. Please consult sales representative for specs that are not listed or please visit www.lekoled.com.

Machine Tolerance $\pm 3\%$ on luminous flux and $\pm 2\text{nm}$ on wavelength.

Spectral Feature (Tc = 25°C)

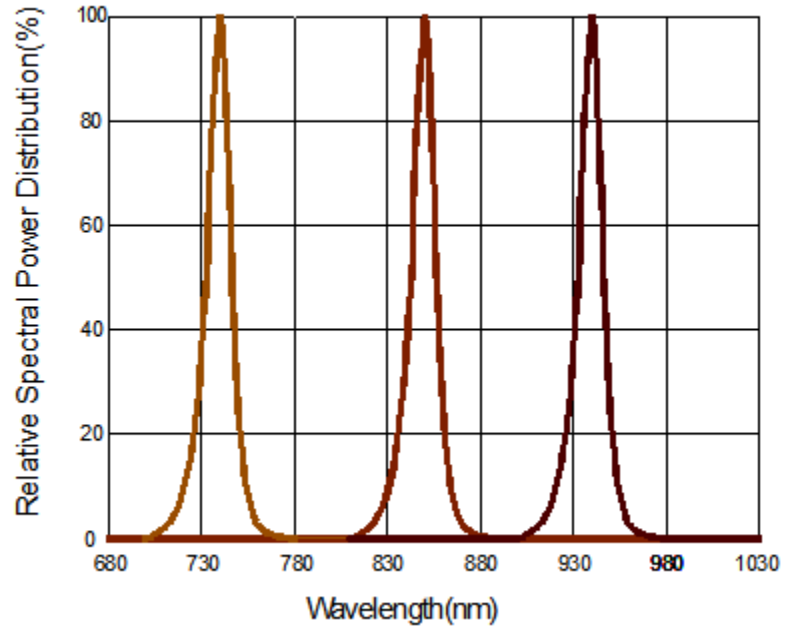

Electrical Features (Tc = 25°C)

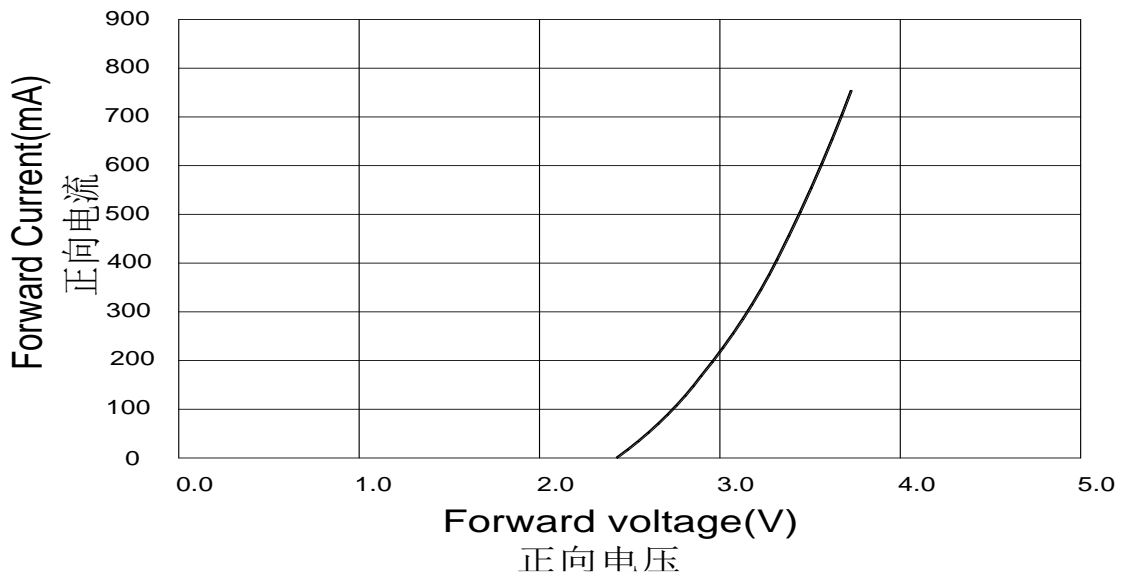

Typical Spatial Distribution (Tc = 25°C)

Intensity Distribution Diagram

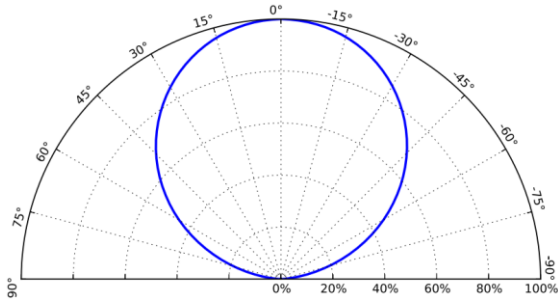

Intensity Distribution Curve

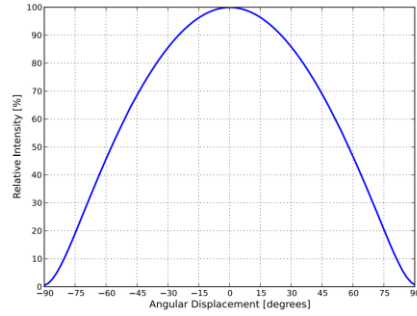

Dimensions (Unit: mm) Tolerance +/-0.5mm

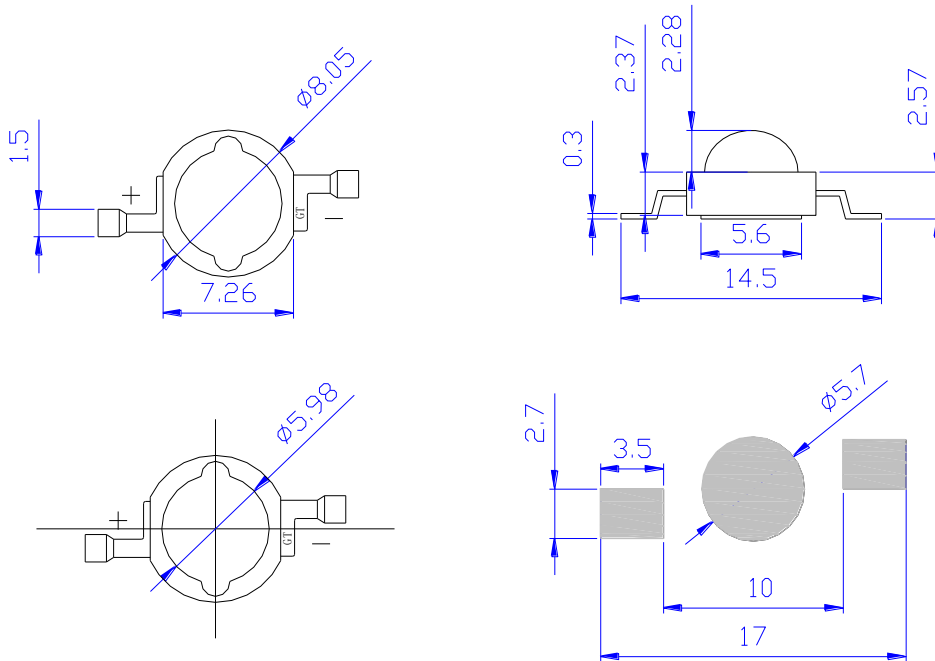

Reflow Soldering

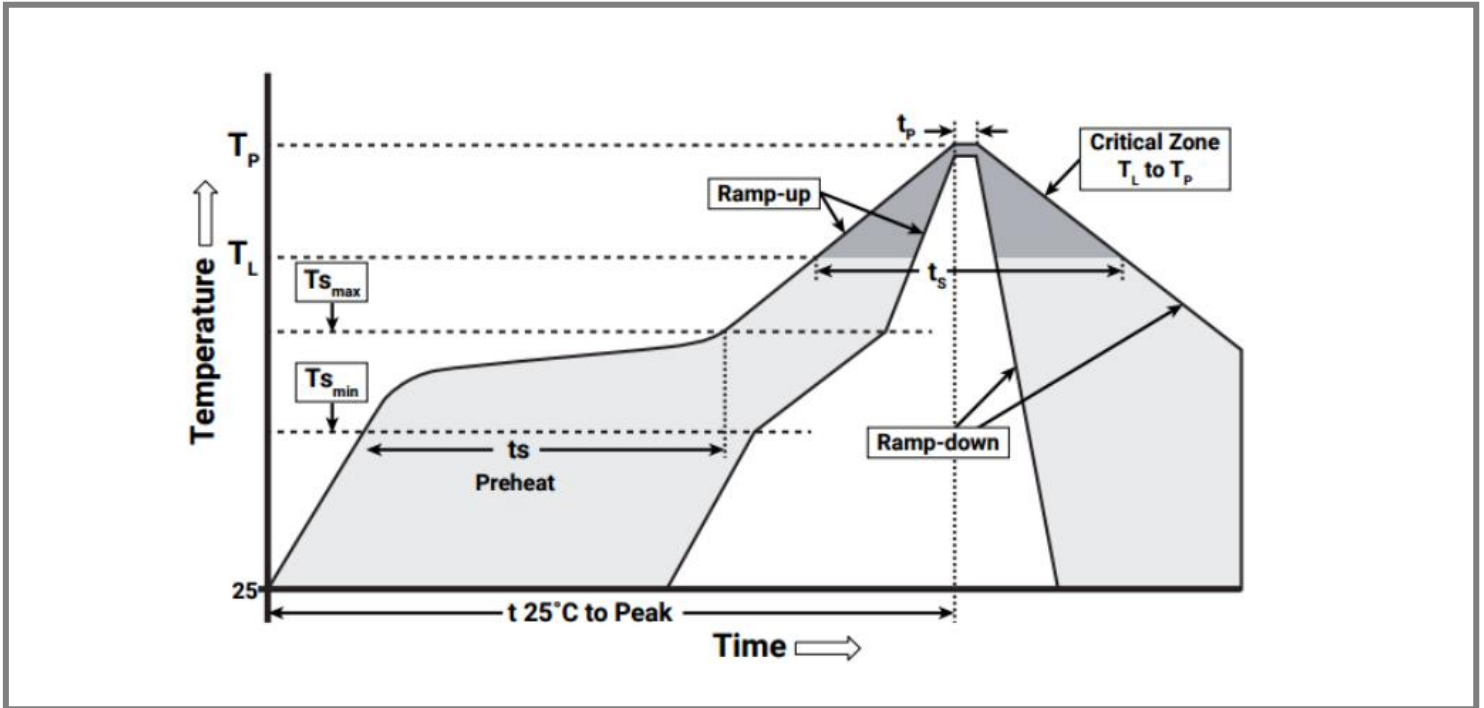

Reflow Soldering Features	Duration (Lead-free)	Soldering Iron	
Ramp up (Ts max to Tp)	3 °C /second max.	Max. Temp	Soldering Time
Preheat: (Tsmin)	90 °C	350°C	3 Seconds/time
Preheat: (Tsmax)	120 °C		
Preheat: (tsmin to tsmax)	60-180 seconds		
Temp Maintenance: (TL)	150 °C		
Time Maintenance :(tl)	60-150 seconds		
Peak Temp (Tp)	180 °C		
(5°C before Reach 180 °C)(tp)	20-40 seconds		
Ramp down	6 °C /second max.		
25°C (Time to Reach Peak Temp)	6 minutes max.		

Notes:
 The operational data provided above are for reference only. The actual operation should be strictly in accordance with product specifications, welding material characteristics fine-tuning parameters in the first test; Be sure to go through the first inspection for mass production, so as to avoid unnecessary losses.

Reliability Tests

Test Items	Test Conditions	Sample Size	Ac/Re
Aging Test	IF=400MA Ta=25°C ×1000hrs	22	0/1
	IF=400MA Ta=85°C ×1000hrs	22	0/1
High Temperature Storage	100°C × 1000 hours	22	0/1
Low Temperature Storage	-40°C × 1000 hours	22	0/1
High Temp & Humidity	IF=400MA 85°C , 85 %RH for 1000 hours	22	0/1
Temperature Shock	-40°C × 30 minutes – +100°C × 30 minutes, 100 cycle	22	0/1
ESD (HBM)	2000V HBM/Time	10	0/1

Criteria for Judging LED Failure(Tc=25°C)

Items	Symbol	Test Conditions	Criteria for Judging LED Failure
Forward Voltage	VF	IF=400MA	>U × 1.1
Reverse Current	IR	VR=5V	IR≥10μA
Luminous Flux	φv	IF=400MA	<S × 0.7

U refers to max value; S refers to initial value.

Notes: Judging criteria based on Tc=25°C .

Packaging (Unit:mm)

Packaging 1: Tube

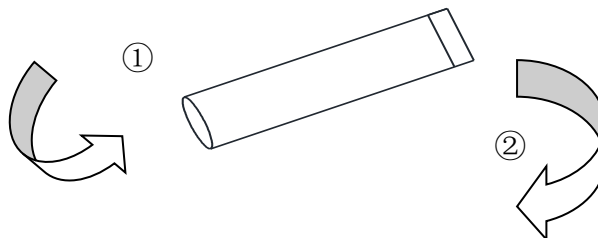
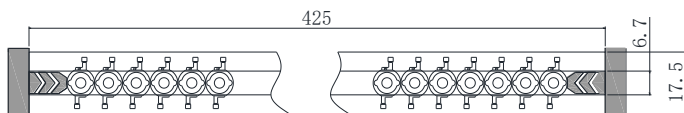

Standard Packaging Details

Tube: 50pcs/tube
 Aluminum Foil Bag: 1000pcs/bag
 Carton: 15Kpcs/carton

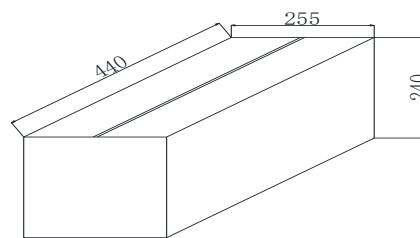

D	24.00	8.30	16.00	5.50	4.70	1.75	11.5	12.00	4.00	2.00	1.50	1.50	0.40
A	±0.05	±0.05	±0.05	±0.05	±0.05	±0.05	±0.05	±0.05	±0.05	±0.05	±0.05	±0.05	±0.05
T													
A	W	A ₀	B ₀	K ₀	K ₁	E	F	P	P ₀	P ₂	D ₀	D _i	T

Packaging 2: Reel

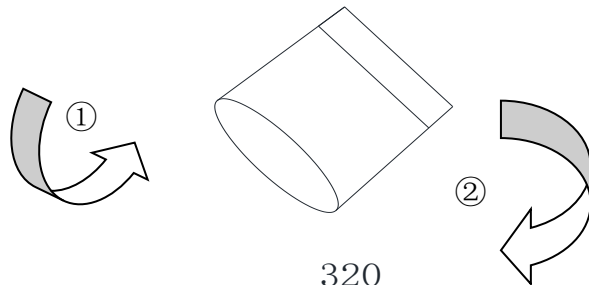
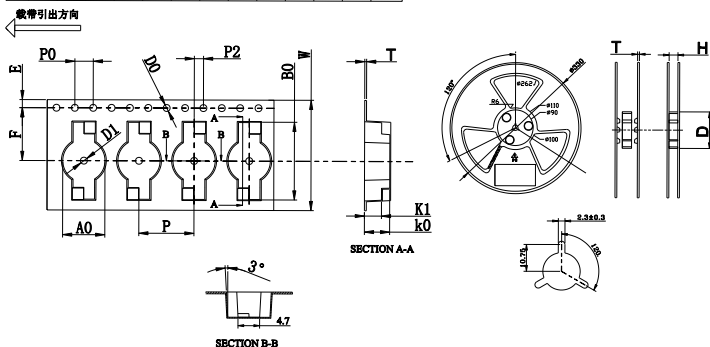

Standard Packaging Details

Reel: 1000pcs/reel
 Carton: 14Kpcs/carton

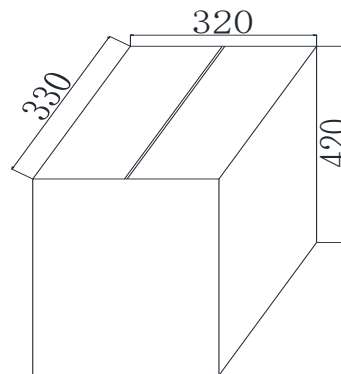

Packaging (Unit:mm)



Packaging 3: Plastic Tray

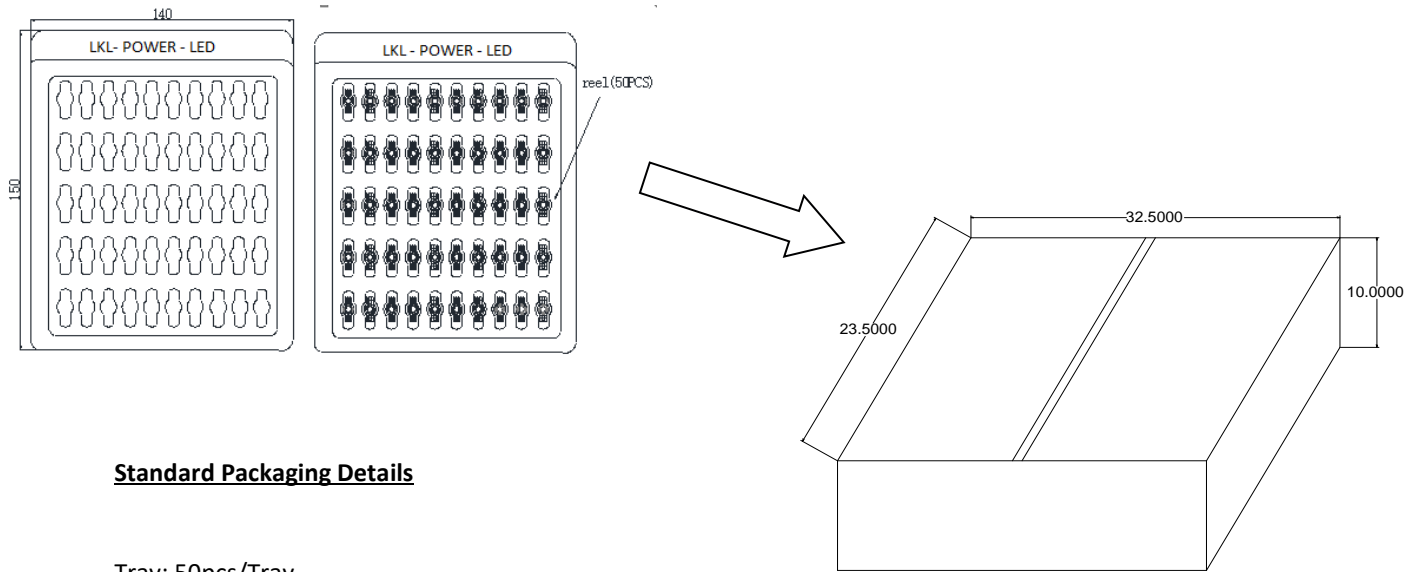

Standard Packaging Details

Tray: 50pcs/Tray
Aluminum Bag: 500pcs/Bag

Notes

Product Specifications

This is a product family data sheet without extra emphasis on a specific model. The specifications in the document refers to its general value under certain test conditions. Please consult sales representative or technical people if encounters specs that are not listed. (Tolerance should be considered.)

Soldering

- (a) Reflow soldering is allowed only once. (Do not use heating platform)
- (b) Do not press the lens when soldering manually.
- (c) Do not squeeze the PCB board after reflow soldering.
- (d) Soldering time should be less than 5 seconds
- (e) Instant test time less than 3 seconds
- (f) Recommend to use thermal grease with conductivity >2.5.
- (g) Please keep the thermal grease inclusion-free;
- (h) Thermal grease spreading area should be a bit larger than the led substrate;
- (i) Thermal grease evenly spread with thickness about 0.1mm;
- (j) Place led flatly and do not push from side in case grease scraped;

Service Conditions

The products must be operated within the rated range of parameters.

Installation

To avoid the led failure or decay to the lighting effects, do not burn the products' light-emitting layer by high temperature soldering iron during installation.

ESD Protection

Statics or surge volt would cause LED failure. When using the products, we suggest wearing anti-static wrist strap or gloves. All devices, equipment and machinery must be grounded. Precautions should be taken to protect the products from the surge voltage generated by the devices. It is recommended to inspect each LED whether it is electrostatic damaged. Inspection can be done by a indicating lamp or low forward current test (suggest 90mA). The destroyed products shows different features, for example, the forward voltage becoming lower, or no light emission under low current.

Heat Dissipation

The thermal design of the end product is particularly important, please consider it seriously. Do avoid high temperature condensation on the product.

Cleaning

Recommend ethanol as the only clean solvent.