

CSP1919 Datasheet

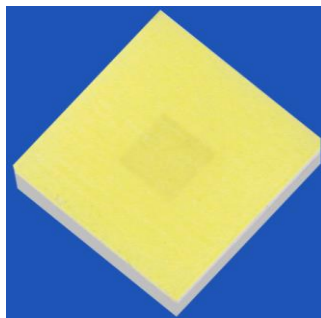

Features:

- High Lumen Output
- High Efficiency Package
- Stable Performance & Great CCT Unity
- Full Spectrum 3000K, 4000K, 5000K,6000K...
- Environmental Friendly; ROHS Compliance

Applications:

- LED Module, Illuminated Advertising
- LED Down Light, Backlight, Ceiling Lamp and other LED Indoor Lights

TABLE OF CONTENTS

PRODUCT NAMING RULES-----	3
CHARACTERISTICS-----	4
CHARACTERISTIC CURVES-----	5
CHARACTERISTIC CURVES-----	6
CHARACTERISTIC CURVES-----	7
CIE BINNING INFORMATION-----	8
RELIABILITY TESTS-----	9
SOLDERING CONDITIONS-----	10
DIMENSION-----	11
PACKAGING-----	12
PRECAUTIONS-----	13

PRODUCT NAMING RULES

LKL	XXX	XXX
LKL	Type	Color Temperature
LEKOLED	CSP1616	W50: 4800-5200K
		...

CHARACTERISTICS

SPECIFICATIONS (IF=120mA, Ta=25°C)

Nominal CCT	Forward Voltage	Forward Current	Lumen	Part Number
5000K	2.7-3.2V	1000mA	380-450LM	LKL-CSP1919W50

Absolute Maximum Ratings at Tj=25°C

Parameters	Symbol	Value	Unit
Power Dissipation	P_D	3500	mW
Forward Current	I_F	1000	mA
Peak Pulsed Forward Current	I_{FP}	1500	mA
Reverse Voltage	V_R	5	V
Viewing Angle	2θ 1/2	120	Deg
Operating Temperature	T_{OPR}	-20 ~ +65	°C
Storage Temperature	T_{STG}	-0 ~ +40	°C
Junction Temperature	T_j	140	°C
Soldering Temperature	T_{SLD}	Reflow Soldering: 230°C or 260°C for 10Sec	

Electrical/ Optical Characteristics at Tj=25°C

Parameters	Symbol	Min	Type	Max	Unit	Condition
Forward Voltage	v_F	2.7	--	3.2	V	IF=1000mA
Reverse Current	I_R		5		μ A	VR=5V
Radiant Flux	Φ_e	380	400	450	LM	IF=1000mA
Color Temperature	CCT	4800		5200	K	IF=1000mA

RELATIVE SPECTRAL POWER DISTRIBUTION

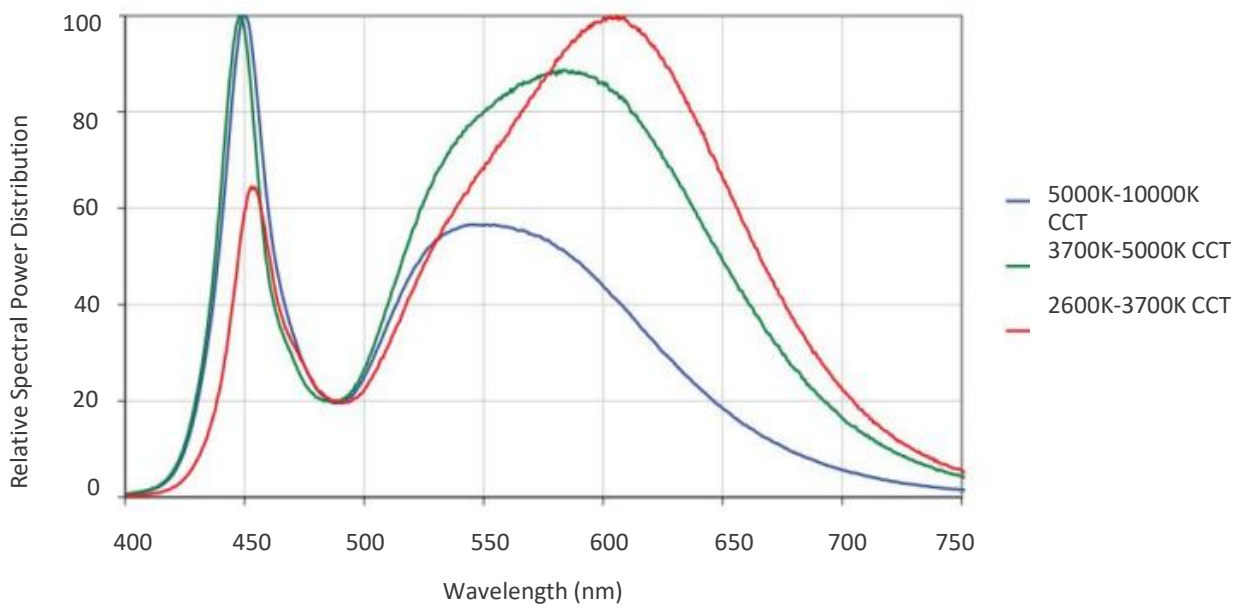

TYPICAL CHARACTERISTIC CURVES

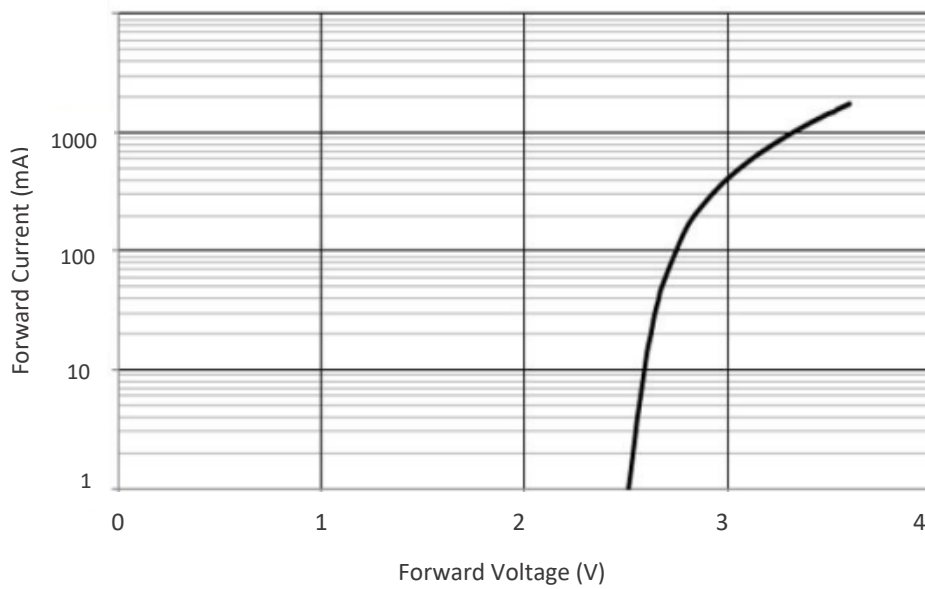
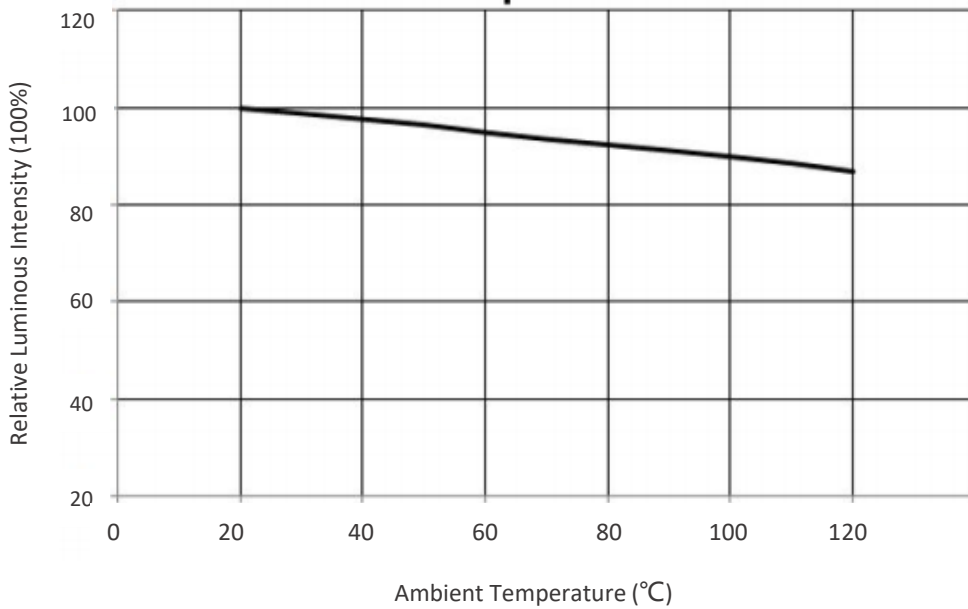

TYPICAL CHARACTERISTIC CURVES

Intensity Distribution Diagram

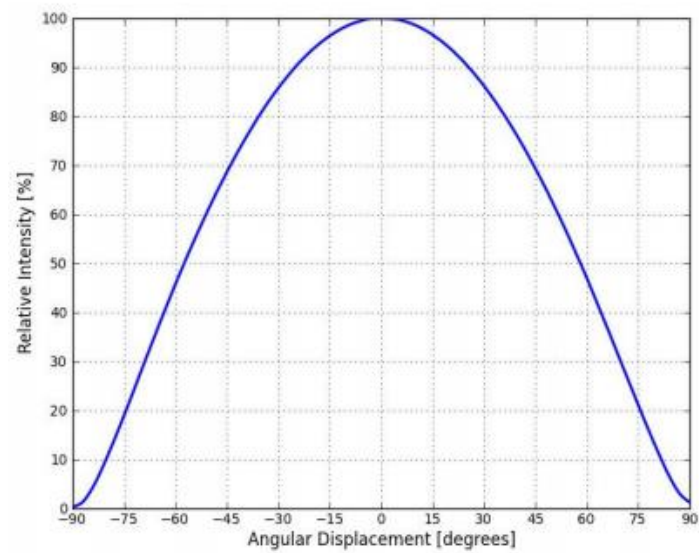
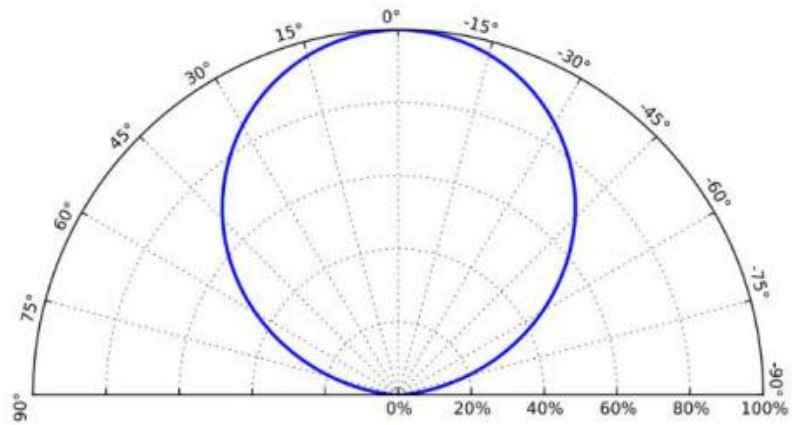

CIE BINNING INFORMATION

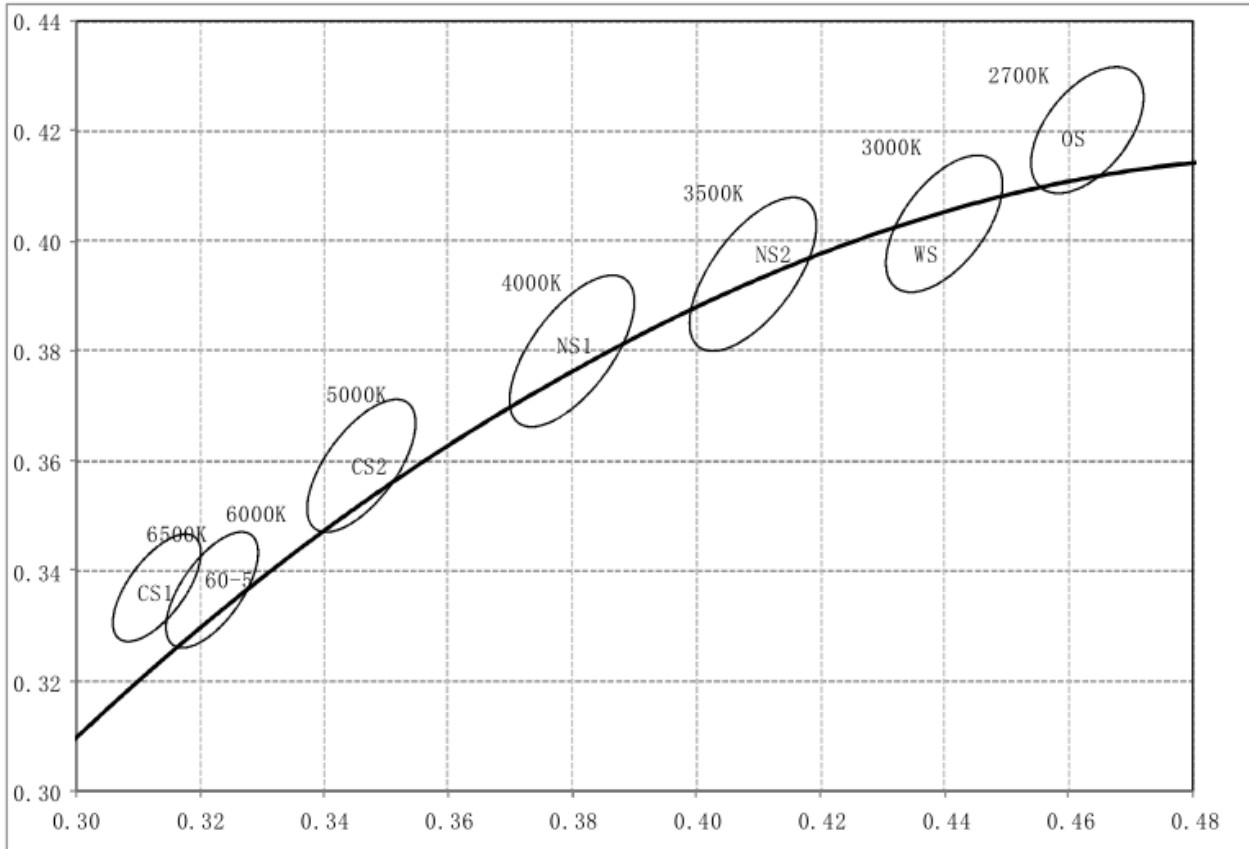

Nominal CCT	Bin Code	Target Center Point (cx,cy)	Major Axis, a	Major Axis, b	Ellipse Rotation Angle, θ	Color Space
6500K	CS1	0.313,0.337	0.01115	0.00475	58.23°	Sing 5-step
6000K	60-5	0.3220,0.3365	0.01179	0.00504	59.21	Sing 5-step
5000K	CS2	0.346,0.359	0.01370	0.00590	59.37°	Sing 5-step
4040K	NS1	0.380,0.380	0.01565	0.00670	54.00°	Sing 5-step
3450K	NS2	0.409,0.394	0.01585	0.00695	52.58°	Sing 5-step
2940K	WS	0.440,0.403	0.01390	0.00680	53.10°	Sing 5-step
2720K	OS	0.463,0.420	0.01290	0.00685	53.17°	Sing 5-step

RELIABILITY TESTS

Test Items	Test Conditions	Sample QTY	Ac/Re
Aging Test	IF=1000mA, Ta=25°C x6000hrs	22	0/1
	IF=1000mA, Ta=85°C x6000hrs	22	0/1
High Temperature Storage	100°C x1000hrs	22	0/1
Low Temperature Storage	-40°C x1000hrs	22	0/1
High Temp & Humidity	IF=1000mA, 85°C, 85% RH for 6000hrs	22	0/1
Temperature Shock	-40°Cx30 min & +100°Cx30 min, 100cycle	22	0/1
ESD(HBM)	2000V HBM/ 1 Time	10	0/1

Criteria for Judging LED Failure (Tc= 25°C)

Items	Symbol	Test Conditions	Criteria for Judging LED Failure
Forward Voltage	VF	IF=1000mA	>U x 1.1
Reverse Current	IR	VR=5V	IR>= 10μA
Lumen	ΦV	IF=1000mA	<S x 0.7

U refers to max value; S refers to initial value.

Notes: Judging criteria based on Tc=25°C.

TYPICAL CHARACTERISTIC CURVES

REFLOW SOLDERING PROFILE

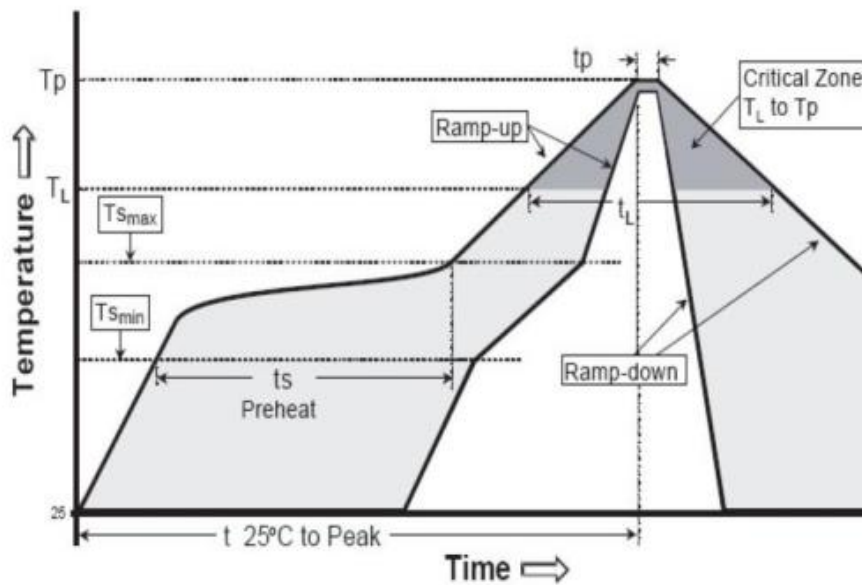

Profile Features	Lead-free solder	Lead solder	Soldering by Manual
Ramp-up Speed(Ts max to Tp)	3 °C/ second max.	3 °C/ second max.	Max. temperature: 350°C 3 seconds/1 time
Preheat: Min. Temperature(Tsmin)	150 °C	100 °C	
Preheat: Max.Temperature(Tsmax)	200 °C	150 °C	
Preheat: Time (tsmin to tsmax)	60~180 seconds	60~120 seconds	
Temperature to Keep: (TL)	217 °C	183 °C	
Time to Keep: (tL)	60~150 seconds	60~150 seconds	
Peak Temperature (Tp)	260 °C	215 °C	
Time within the peak temperature (tp)	20~40 seconds	10~30 seconds	
Ramp-down Speed	6°C/ second max.	6°C/ second max.	
Time to the peak Temperature	8 minutes max.	6 minutes max.	

DIMENSIONS

Unit: mm

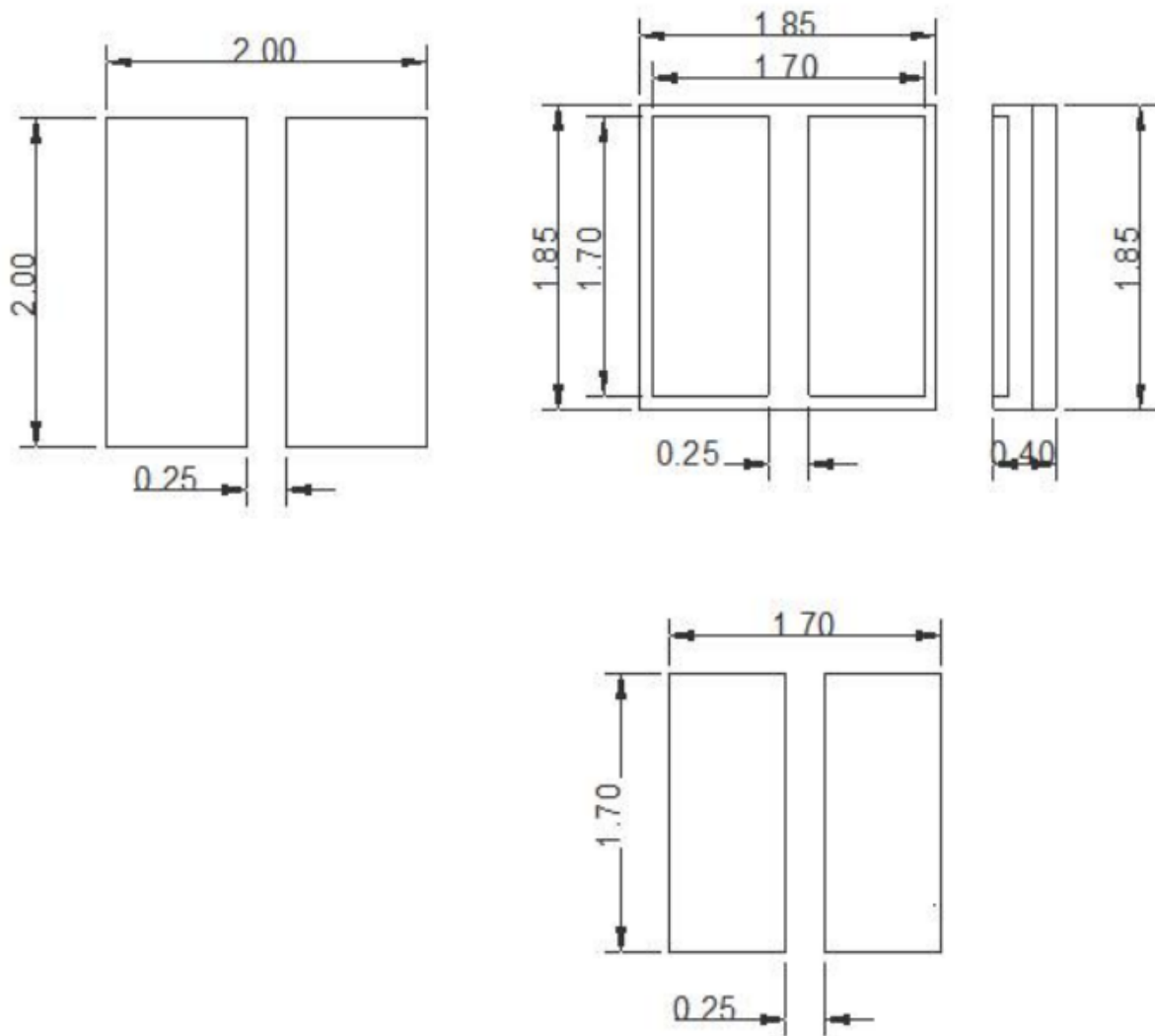

Notes :

*All dimensions are in millimeters.(tolerance:±0.2mm)

*The appearance and specifications of the product may be changed for improvement without notice.

PACKAGING

Tape Specifications (Units : mm)

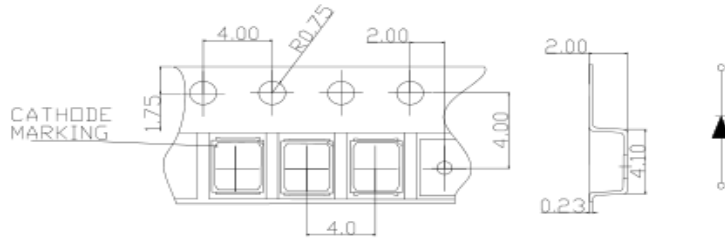

Reel Dimensions

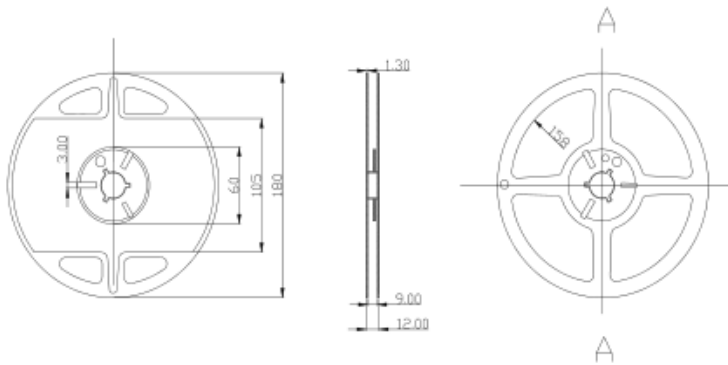

Moisture Resistant Packaging

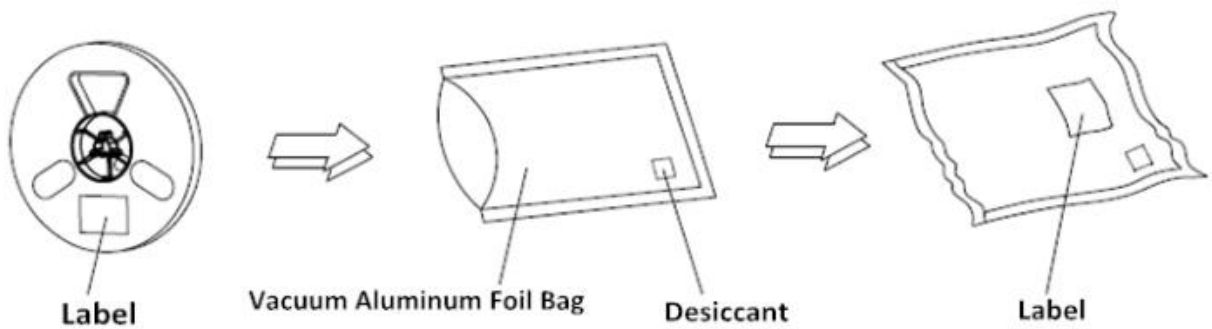

PRECAUTIONS

Caution

1. Wave peak and soak-stannum soldering etc.is not suitable for this products.
2. reflow solding should not be done more than one time
3. The peak reflow temperature is $260\pm 10^{\circ}\text{C}$, not more than 40 seconds
4. Repairing should not be done after the LEDs have been soldered. When repairing is un avoidable, suitable tools have to be used.
5. When solding,do not put stress on the LEDs during heating.
6. After soldering, do not warp the LED.do not stack PCBS or assemblies containg K Series LEDS so that anything rests on the LED.

Test

1. Drive IFP Conditions: Pulse Width $\leq 10\text{msec}$ duty $\leq 1/10$.
2. All high power emitter LED products mounted on aluminum metal-core printed circuit board, can be lighted directly, but we do not recommend lighting the high power products for more than 5 seconds without a appropriate heat dissipation equipment.

Precaution for use

Storage

To avoid the moisture penetration ,we recommend storing LEDs in a dry box (or a desiccator) with adesiccant. The recommended conditions are temperature 5 to 30 degrees Centigrade. Humidity 60% maximum.

Precaution after opening packing

1. Soldering should be done right after opening the package (within 24Hrs).
2. Keeping of a fraction.
Sealing; Temperature: $5\sim 30^{\circ}\text{C}$, Humidity: less than 30%
If the package has been opened than 1 week , should be dried for 10-12Hrs at $60\pm 5^{\circ}\text{C}$
3. Any mechanical force or any excess vibration shall not be accepted to apply during cooling process tonormal temperature after soldering.
3. Thermal Design is paramount importance because heat generation may result in the Characteristics decline, such as brightness decreased, Color changed and so on. Please consider the heat generation of the LEDs when making the system design.
4. Please avoid rapid cooling after soldering.
5. Components should not be mounted on warped direction of PCB.
6. This device should not be used in any fluid such as water, oil ,organic solvent etc. When washing is required, Isopropyl Alcohol should be used.
7. Avoid touching Lens parts especially by sharp tools such as pincette.
- 8.Please do not force over 1000g impact or pressure diagonally on the silicone lens. It will cause fataldamage on this product.
- 9.Please do not cover the silicone resin of the LEDs with other resin.