

3535 Color LED Datasheet

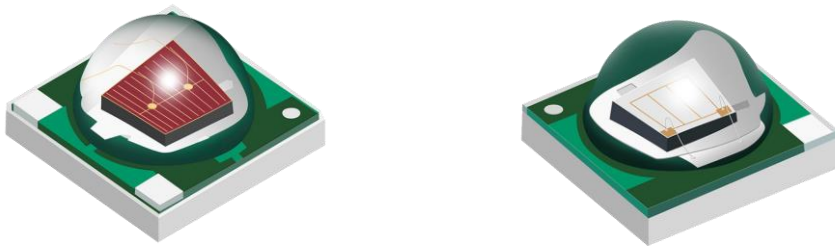

Features:

- Slim Size SMD Package: Design Flexibility
- Wavelength: 365-850nm
- Light Color: Red, Green, Blue, Yellow, Amber, UV, IR...
- Ceramic Base & Low Thermal Resistance
- Wide Color Temperature Range
- Environmental Friendly; ROHS Compliance
- Customized Service Available

Applications:

- Flash Light, Obstruction Lights, Airport Warning Lights,
 - Flood Light, High Bay Light, Tunnel Light and other LED Outdoor Lights
 - LED Aquarium Light, LED Plant Growing Light..
-

TABLE OF CONTENTS

PRODUCT NAMING RULES-----	3
CHARACTERISTICS-----	4
LUMINOUS FLUX CHARACTERISTIC-----	5
CHARACTERISTIC CURVES-----	6
CHARACTERISTIC CURVES-----	7
RELIABILITY TESTS-----	8
SOLDERING CONDITIONS-----	9
DIMENSION-----	10
PACKAGING-----	11
PRECAUTIONS-----	12
PRECAUTIONS-----	13

PRODUCT NAMING RULES

LKL	XXXX	XX	X	X	X	XXX
LKL	Type	Color	Chip Size	Chip QTY	Beam Angle	Brightness
LEKOLED	3535	V1: 365-370nm	2: 28mil	1: 1EA	0: 120°	10: 10-20LM
		V2: 370-380nm	3: 30/35mil	2: 2EA		20: 20-30LM
		V3: 380-390nm	4: 40/42/45mil			30: 30-50LM
		V4: 390-400nm				...
		V5: 400-410nm				70: 70-80LM
		V6: 410-420nm				80: 80-100LM
		RB: 440-450nm				...
		B2: 450-460nm				
		B3: 460-470nm				
		G2: 520-530nm				
		Y4: 590-595nm				
		A6: 600-610nm				
		DR: 660-665nm				
		IR1: 730-740nm				
		IR3: 840-860nm				
		...				

CHARACTERISTICS

Parameter	Unit	Min	Typical	Max
Power Dissipation 1	mW		1000	
Power Dissipation 2	mW		3000	
Forward Current 1	mA		350	
Forward Current 2	mA		700	
Forward Voltage	V	2,8		3,6
Reverse Voltage	V			5
Wavelength (UV)	nm	365		420
Wavelength (IR)	nm	730		860
Wavelength(Red, Green, Blue, Yellow)	nm	440		660
Beam Angle $2\theta_{1/2}$	deg.		120	
Thermal Resistance	$^{\circ}\text{C}/\text{W}$		4	
Junction Temperature T_j	$^{\circ}\text{C}$			150
Operating Temperature T_{op}	$^{\circ}\text{C}$	-40		+60
Storage Temperature T_{st}	$^{\circ}\text{C}$	-40		+85
ESD (HBM)	V		8000	
Reflow Soldering (Lead-Free) T_{ST}	$^{\circ}\text{C}$			240

LUMINOUS FLUX CHARACTERISTIC

Specifications (Tc=25°C)

Light Color	Wavelength (nm)	2.8-3.4V @350mA	1W Model No.	3.2-4.0V @700mA	3W Model No.
		LM		LM	
Blue	450-460	1. 10-15 2. 15-20	1. LKL-3535B231010 2. LKL-3535B231015	1. 20-30	1. LKL-3535B241020
Blue	460-470	1. 10-15 2. 15-20	1. LKL-3535B331010 2. LKL-3535B331015	1. 20-30	1. LKL-3535B341020
Green	520-530	1. 50-70 2. 70-90	1. LKL-3535G231050 2. LKL-3535G231070	1. 100-130 2. 140-160	1. LKL-3535G2410100 2. LKL-3535G2410140

Light Color	Wavelength (nm)	2.0-2.6V @350mA	1W Model No.	2.2-2.8V @700mA	3W Model No.
		LM		LM	
Yellow	590-595	1. 40-50	1. LKL-3535Y431040	1. 50-70	1. LKL-3535Y441050
Red	620-630	1. 30-40 2. 40-60	1. LKL-3535R131030 2. LKL-3535R131040	1. 70-90	1. LKL-3535R141070
Deep Red	660-665	1. 20-30 2. 30-50	1. LKL-3535DR31020 2. LKL-3535DR41030	1. 50-60	1. LKL-3535DR41050

Light Color	Wavelength (nm)	1.5-1.8V @350mA	1W Model No.	1.7-2.0V @700mA	3W Model No.
		LM		LM	
IR	730-740	1. 10-20	1. LKL-3535IR141010	1. 20-30	1. LKL-3535IR141020
IR	840-860	/	1. LKL-3535IR33 2. LKL-3535IR34	/	1. LKL-3535IR34

TYPICAL CHARACTERISTIC CURVES

Relative Spectral Power Distribution (Tc=25°C)

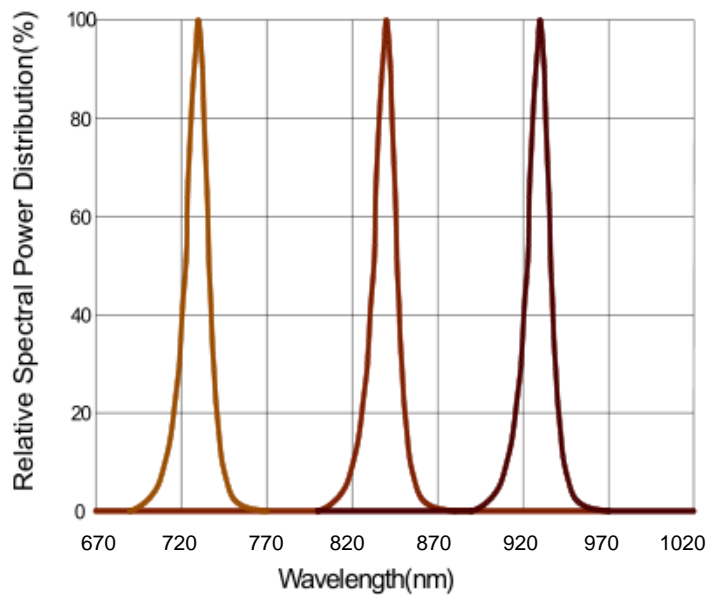
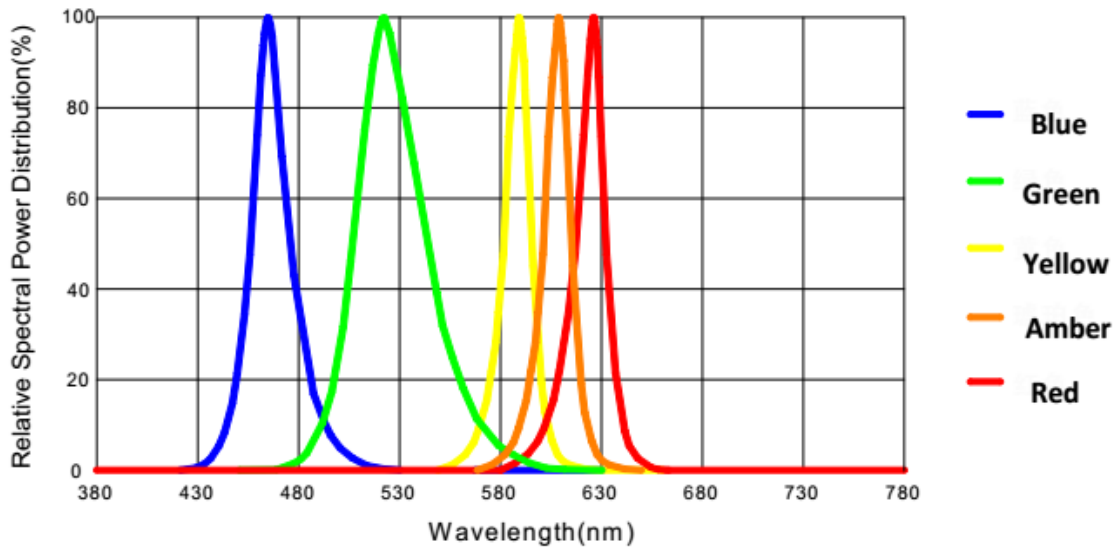

TYPICAL CHARACTERISTIC CURVES

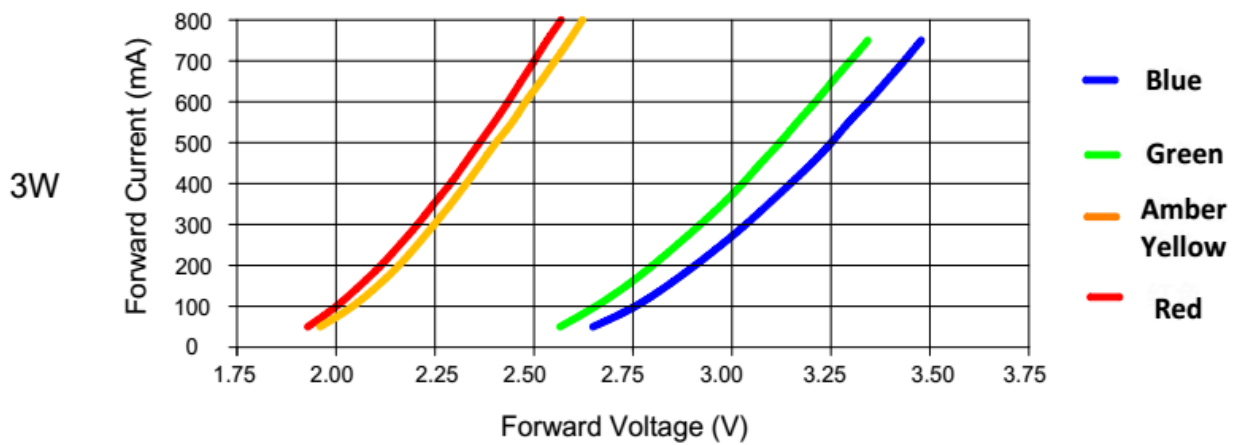
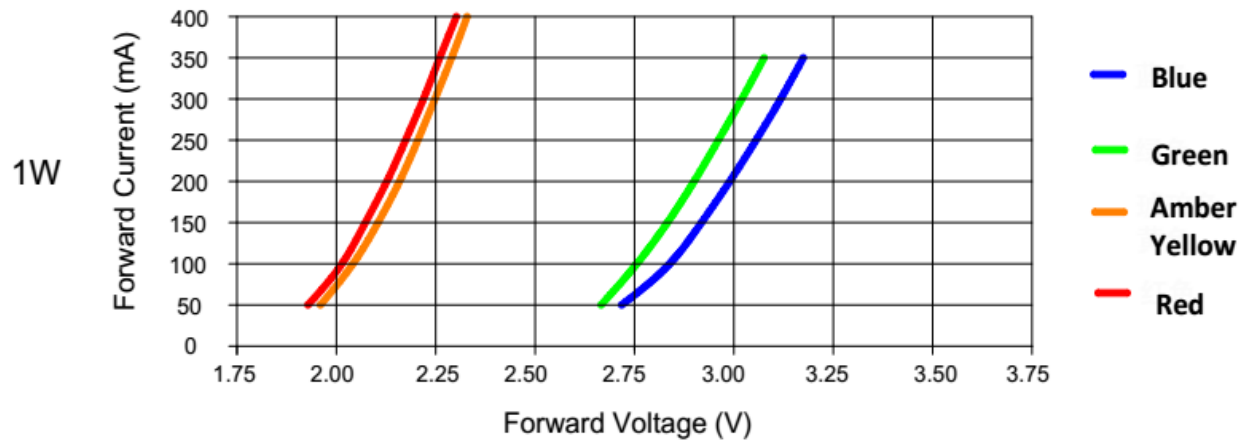

RELIABILITY TESTS

Test Items	Test Conditions	Sample QTY	Ac/Re
Aging Test	IF=350-700mA, Ta=25 °C x6000hrs	22	0/1
	IF=350-700mA, Ta=85 °C x6000hrs	22	0/1
High Temperature Storage	100 °C x1000hrs	22	0/1
Low Temperature Storage	-40 °C x1000hrs	22	0/1
High Temp & Humidity	IF=350-700mA, 85 °C, 85% RH for 6000hrs	22	0/1
Temperature Shock	-40 °C x30 min & +100 °C x30 min, 100cycle	22	0/1
ESD(HBM)	2000V HBM/ 1 Time	10	0/1

Criteria for Judging LED Failure (Tc= 25 °C)

Items	Symbol	Test Conditions	Criteria for Judging LED Failure
Forward Voltage	VF	IF=350-700mA	>U x 1.1
Reverse Current	IR	VR=5V	IR>= 10µA
Lumen	ΦV	IF=350-700mA	<S x 0.7

U refers to max value; S refers to initial value.

Notes: Judging criteria based on Tc=25 °C.

TYPICAL CHARACTERISTIC CURVES

REFLOW SOLDERING PROFILE

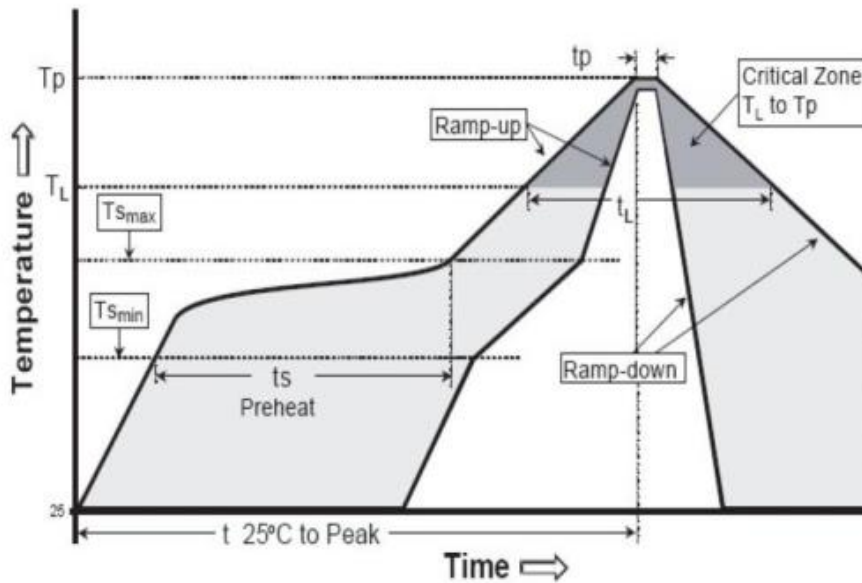

Profile Features	Lead-free solder	Lead solder	Soldering by Manual
Ramp-up Speed(T_s max to T_p)	3 °C/ second max.	3 °C/ second max.	Max. temperature: 350°C 3 seconds/1 time
Preheat: Min. Temperature(T_{smin})	150 °C	100 °C	
Preheat: Max. Temperature(T_{smax})	200 °C	150 °C	
Preheat: Time (t_{smin} to t_{smax})	60~180 seconds	60~120 seconds	
Temperature to Keep: (T_L)	217 °C	183 °C	
Time to Keep: (t_L)	60~150 seconds	60~150 seconds	
Peak Temperature (T_p)	260 °C	215 °C	
Time within the peak temperature (t_p)	20~40 seconds	10~30 seconds	
Ramp-down Speed	6°C/ second max.	6°C/ second max.	
Time to the peak Temperature	8 minutes max.	6 minutes max.	

DIMENSIONS

Unit: mm

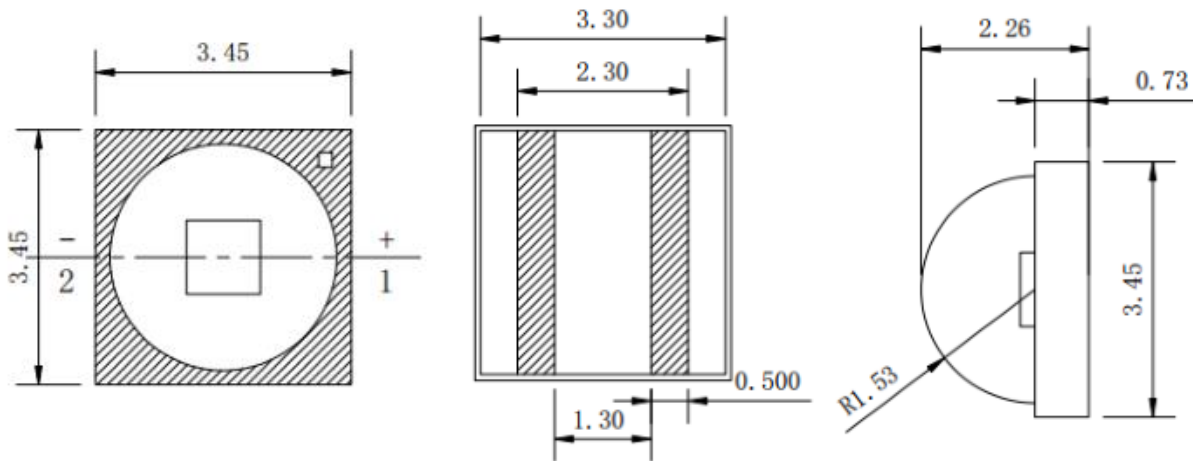

Soldering Pad Dimension

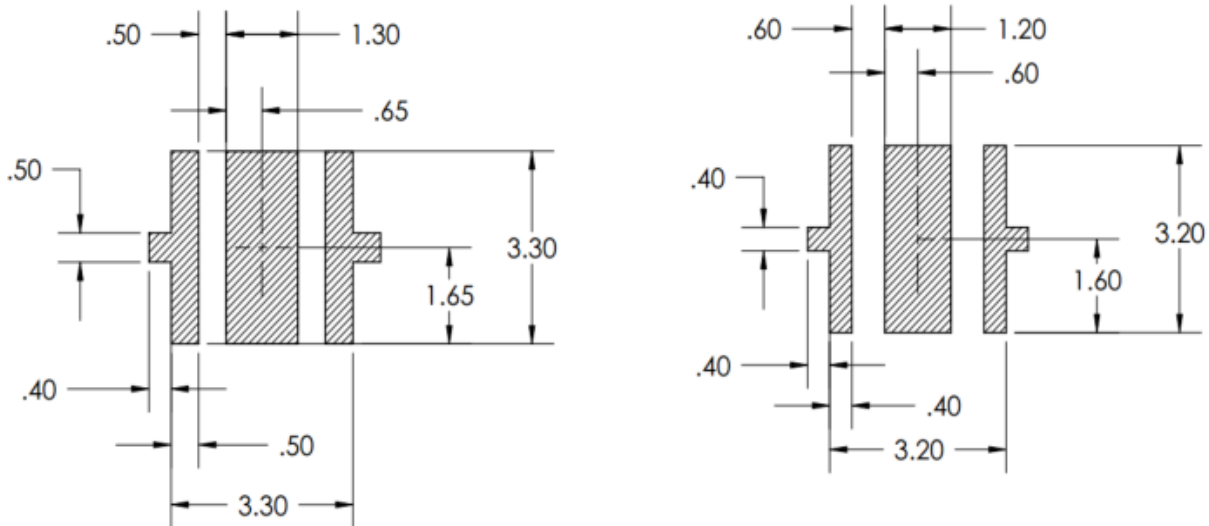

Notes :

*All dimensions are in millimeters.(tolerance:±0.2mm)

*The appearance and specifications of the product may be changed for improvement without notice.

PACKAGING

Tape Specifications (Units : mm)

Standard Package: 1000PCS/REEL (7 inches)

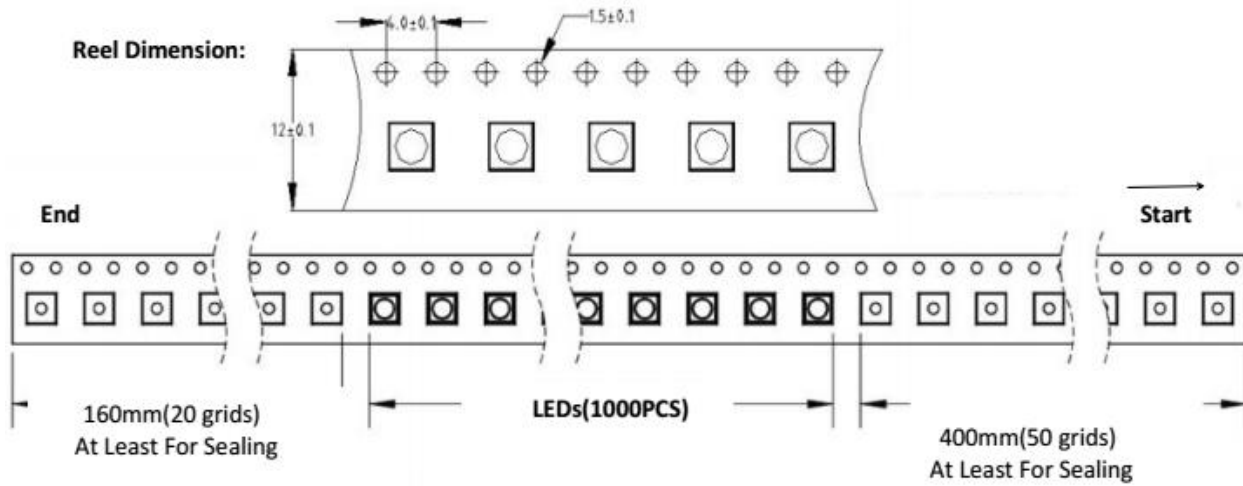

Reel Dimensions

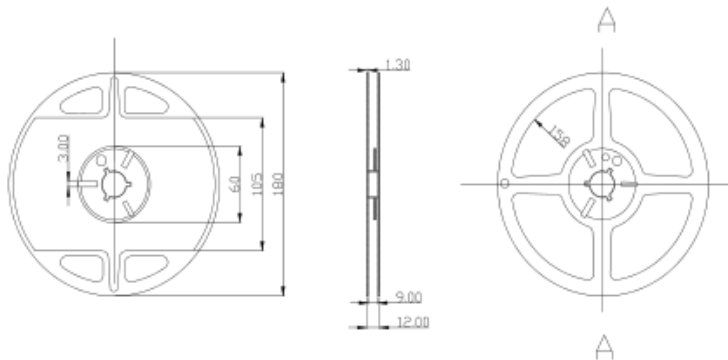

Moisture Resistant Packaging

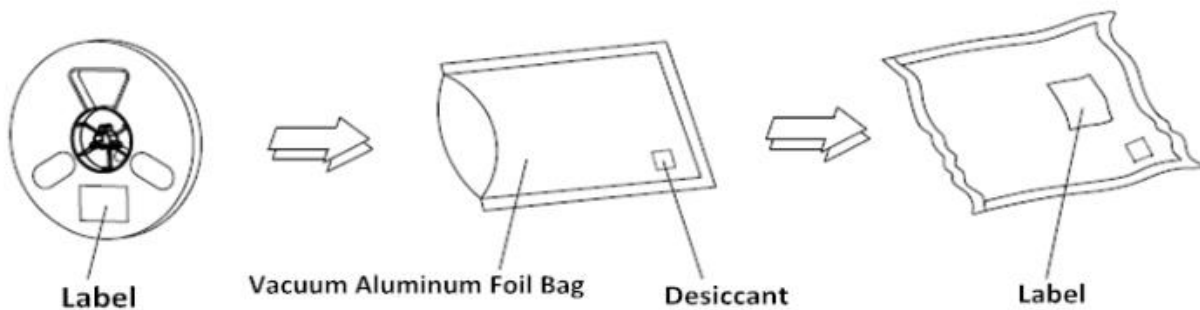

PRECAUTIONS

Storage Condition

1. Product should be stored in a dry, less than 30% relative humidity environment, storage temperature 5~30°C.
2. Avoid damaging the vacuum bags by the external force, in case of flat bags and being affected with damp.
3. Guard against damp, if it is, there is a need to put the reel patch in 60°C oven for 24 hours; After taking out the reel from the package, the lamp should be welded within 12 hours at best.
4. LEDs, already taking out from the original package but without being welded, should be stored in any of the following ways:
 - a. After opening, the LED lamp can be sealed in the original vacuuming bags again.
 - b. Put component into the solid metal container with closed lid for storage, fresh desiccant and humidity card should be put in the container at the same time, and test the related humidity less than 30%.
 - c. Put component into dry cabinet or container purified by nitrogen, and the cabinet or container can effectively keep the relative humidity below 30%.
 - d. Reflow soldering should be finished within 24 hours after opening the package, and workshop condition should be less than or equal to 30°C/60%RH.
 - e. If there is no environment with relative humidity less than 30% for storage, it needs to bake for one hour before reflow soldering.
5. Stacking PCB or components of LEDs containing X series, don't drop all the weight on the lens of lamp. The force on the lens can lead to lamp falling off, and at least 2cm should be set aside above LED lens. Also, foam wrapping paper shouldn't be used directly on the lamp, LEDs may be damaged by the force from the foam wrapping paper.

Reflow Soldering Conditions

1. PCB board should be prepared or cleaned according to manufacturer's standards, then LED lamp can be put or welded on the PCB.
2. Our company LED design is used for welding on the PCB by reflow soldering. Reflow soldering can be finished in the reflow furnace, or put the PCB on the hot plate and operate according to the reflow soldering temperature curve.
3. Pay attention to reflow soldering conditions when using, the reflow soldering temperature should be debugged before using reflow soldering. Reflow soldering condition: preheating temperature 100~150°C, reflow soldering temperature 230~260°C, welding time within 10sec. Operators should receive electrostatic protective measures, and all equipment must be reliable grounding.
4. Reflow soldering is no more than 2 times.
5. Force and pressure should not be exerted on the lamp when carrying out reflow soldering.
6. PCB can not be packaged immediately after reflow soldering, and there needs natural cooling for PCB and lamp.

Cleaning after Reflow Soldering

1. Lamp should be cooled to room temperature after welding, then carrying out subsequent processing. Early to deal with the component, especially the part around the lens, may lead to damage of product.

PRECAUTIONS

2. The consistency of the weld is suggested to check. After avoiding the selected components on printed circuit boards, it seems to achieve full circle during welding process(no obvious welding particles). Looking from the back of package and PCB, empty holes should be seen hardly in welding area.
3. When cleaning PCB after welding, isopropyl alcohol can be used to clean PCB but without ultrasonic cleaning. Also the PCB board already equipped with lamps can not be cleaned by water.
4. Don't use the following chemicals for cleaning:
 - a. Chemicals that may lead to outgassing of aromatic hydrocarbon compounds(such as toluene, xylene)
 - b. Methyl acetate and ethyl acetate (i.e., nail cream cleaner)
 - c. Cyanoacrylate (i.e., the super glue)
 - d. Ethylene glycol (including Radio Shack ® precision electronic cleaning agent)
 - e. PLIOBOND ® adhesives

Installation Methods

1. White LED has anti-static requirements, so corresponding anti-static measures should be taken during the process of installation and use.
2. Pay attention to the exterior line arrangement of all kinds of devices to avoid wrong polarity. Devices can't be too close to the heating elements, and working conditions can not exceed the prescribed limits.
3. When deciding to install in the hole, the size and tolerance of hole and distance between holes on PCB need to be well calculated to avoid excessive pressure forcing on the plate.
4. Avoid any vibration and external force on LED.

Working Conditions

1. In order to make LED work under a stable condition, protective resistance must be in series, and the resistance can be measured by supplied voltage or current of LED. LED working voltage and current are endowed by specifications of different LEDs.
2. There needs the circuit design to be carried out to prevent super voltage(or super current) when witching LEDs, short current or pulse current can both damage the connection of LED.
3. When LED source working, ambient temperature can affect the reliability of life, so please keep away from the heat source at work. At the same time, surface temperature is required to keep within 60°C .
4. Based on the incompatible volatile organic compounds existing in the LED solid-state lighting design, these may weaken the performance of the lighting system and shorten its service life, so please avoid using organic compounds during the process of design and working.

Other matters

1. This product is silicon encapsulation, so please avoid hard objects extrusion.
2. All the equipments contacting LED must be grounded, and operators must wear grounded anti-static gloves, anti-static shoes and anti-static clothing.