

3030 Color Series Datasheet



Features:

- Slim Size SMD Package: Design Flexibility
- High Lumen Output and High Radiant Flux
- Stable Performance & Great CCT Unity
- R, G, B, Y, A, UV, IR Light Color Available
- Full Wavelength 365-850nm Available
- Environmental Friendly; ROHS Compliance
- Customized Service Available

Applications:

- LED Module, Illuminated Advertising
- Tube Light, Panel Light, Ceiling Lamp and other LED Indoor Lights
- Flood Light, High Bay Light, Tunnel Light and other LED Outdoor Lights
- LED Aquarium Light, LED Plant Growing Light..

TABLE OF CONTENTS

PRODUCT NAMING RULES-----	3
CHARACTERISTICS-----	4
LUMINOUS FLUX CHARACTERISTIC-----	5
CHARACTERISTIC CURVES-----	6
CHARACTERISTIC CURVES-----	7
RELIABILITY TESTS-----	8
SOLDERING CONDITIONS-----	9
DIMENSION-----	10
PACKAGING-----	11
PRECAUTIONS-----	12

PRODUCT NAMING RULES

LKL	XXXX	XX	X	X	XXX
LKL	Type	Light Color	Chip QTY	Beam Angle	Brightness
LEKOLED	3030	V1: 360-370nm	1: 1EA	0: 120°/140°	10: 10-12LM
		V2: 375-385nm	2: 2EA		12: 12-14LM
		V3: 390-400nm	3: 3EA		20: 20-22LM
		V4: 400-410nm		35: 35-40LM
		V5: 410-420nm			70: 70-80LM
		RB: 440-450nm		
		B2: 450-460nm			50M: 50-100mcd
		B3: 460-470nm			20M: 200-250mcd
		G2: 520-530nm			500M: 500-550mcd
		Y4: 585-595nm			800M: 800-850mcd
		A6: 600-610nm		
		R1: 620-630nm			
		DR: 660-665nm			
		IR1: 730-740nm			
		IR3: 850nm			
				

CHARACTERISTICS

Parameter	Unit	Min	Typical	Max
Power Dissipation	mW		1050	
Forward Current	mA		350	
Forward Voltage	V	1,6		3,4
Wavelength	nm	360		850
Beam Angle 2 θ 1/2	deg.		120	
Reverse Current	uA			10
Reverse Voltage	V			5
Operating Temperature Top	°C	-40		+60
Storage Temperature Tst	°C	-40		+85
Junction Temperature Tj	°C			120
ESD (HBM)	V			2000
Related thermal resistance Rj-c	°C/W		8	
Reflow Soldering (Lead-Free) ST	°C			260

LUMINOUS FLUX CHARACTERISTIC

Specifications (IF=350mA, Tc=25°C)

Light Color	Wavelength (nm)	2.8-3.4V @350mA	Model No.
		Luminous Flux	
Royal Blue	440-450	17-20LM	LKL-3030RB1017
Lake Blue	450-460	12-15LM	LKL-3030B21012
Blue	460-470	12-15LM	LKL-3030B31012
Green	520-530	70-80LM	LKL-3030G21070
Phosphor Green	520-530	180-190LM	LKL-3030PG10180

Light Color	Wavelength (nm)	2.0-2.6V @350mA	Model No.
		Luminous Flux	
Yellow	590-595	22-25LM	LKL-3030Y42022
Amber	600-610	20-22LM	LKL-3030A62020
Red	620-630	30-35LM	LKL-3030R11030
Deep Red	660-665	12-15LM	LKL-3030DR2012

Light Color	Wavelength (nm)	2.0-2.2V @350mA	Model No.
		Luminous Flux	
Infrared Red	730-740	200-300MCD	LKL-3030IR120200M

Light Color	Wavelength (nm)	2.8-3.4V @350mA	Model No.
		Luminous Flux	
UV	365-370	800-850MCD	LKL-3030V120800M
UV	390-400	7-9LM	LKL-3030V31007

RELATIVE SPECTRAL POWER DISTRIBUTION

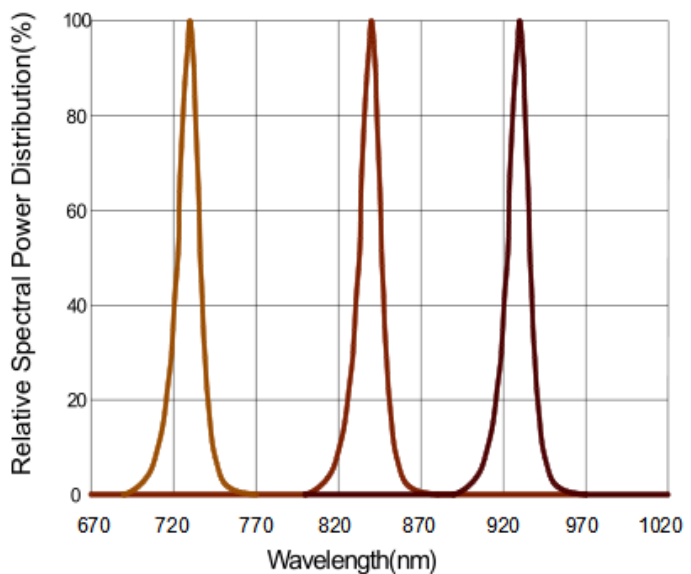
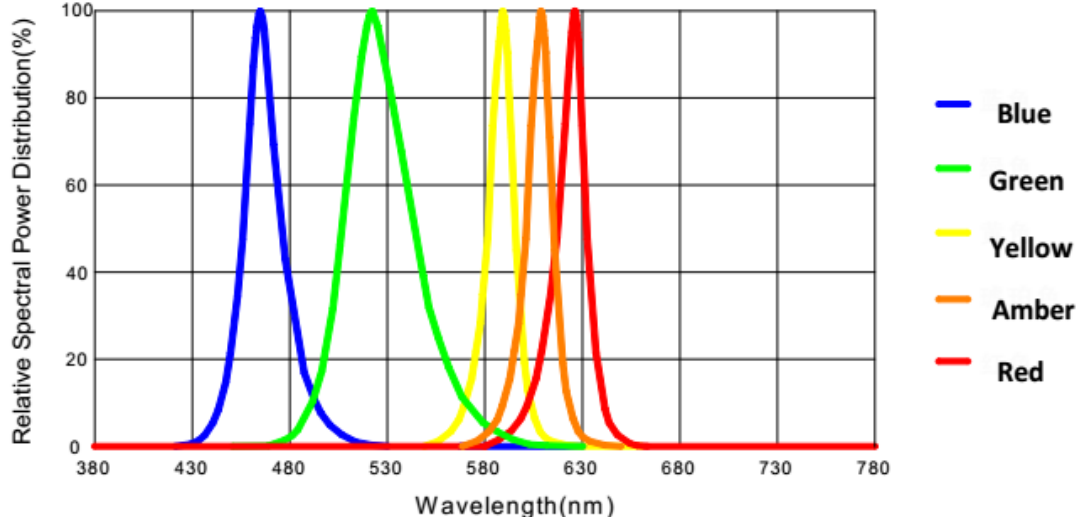

TYPICAL CHARACTERISTIC CURVES

Specifications (IF=350mA, Tc=25°C)

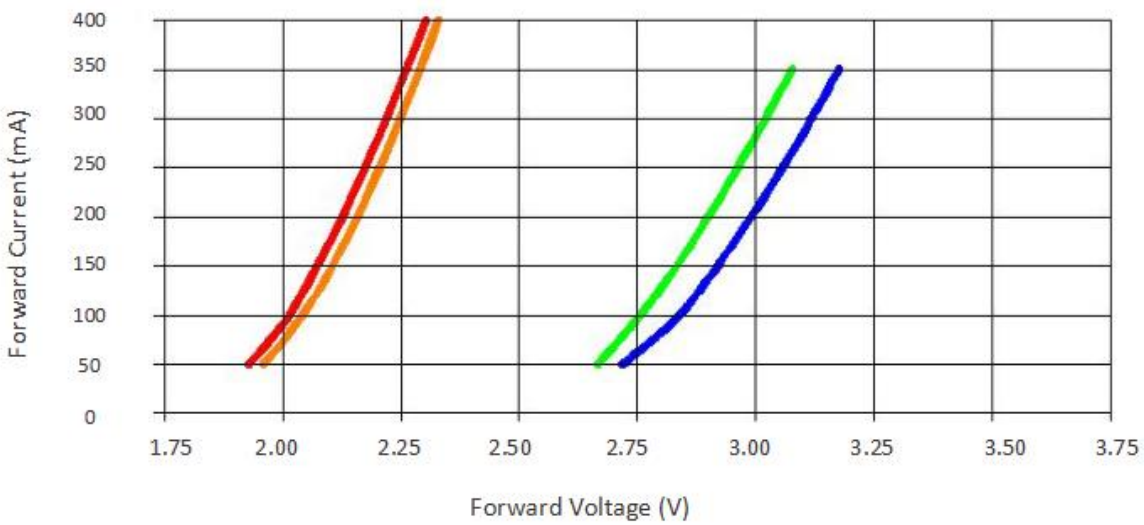
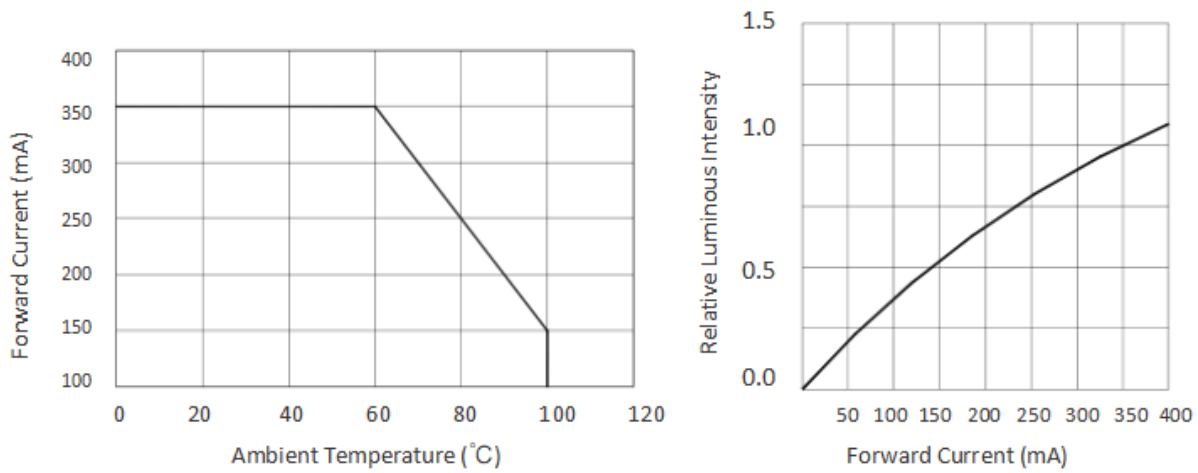

RELIABILITY TESTS

Test Items	Test Conditions	Sample QTY	Ac/Re
Aging Test	IF=350mA, Ta=25°C x6000hrs	22	0/1
	IF=350mA, Ta=85°C x6000hrs	22	0/1
High Temperature Storage	100°C x1000hrs	22	0/1
Low Temperature Storage	-40°C x1000hrs	22	0/1
High Temp & Humidity	IF=350mA, 85°C, 85% RH for 6000hrs	22	0/1
Temperature Shock	-40°Cx30 min & +100°Cx30 min, 100cycle	22	0/1
ESD(HBM)	2000V HBM/ 1 Time	10	0/1

Criteria for Judging LED Failure (Tc= 25°C)

Items	Symbol	Test Conditions	Criteria for Judging LED Failure
Forward Voltage	VF	IF=350mA	>U x 1.1
Reverse Current	IR	VR=5V	IR>/= 10μA
Lumen	ΦV	IF=350mA	<S x 0.7

U refers to max value; S refers to initial value.

Notes: Judging criteria based on Tc=25°C.

TYPICAL CHARACTERISTIC CURVES

REFLOW SOLDERING PROFILE

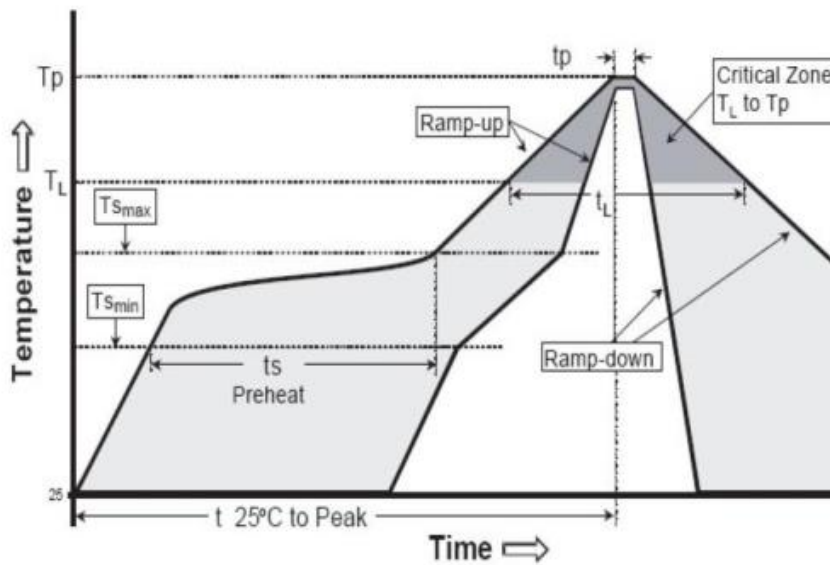

Profile Features	Lead-free solder	Lead solder	Soldering by Manual
Ramp-up Speed(Ts max to Tp)	3 °C/ second max.	3 °C/ second max.	Max. temperature: 350°C 3 seconds/1 time
Preheat: Min. Temperature(Tsmin)	150 °C	100 °C	
Preheat: Max. Temperature(Tsmax)	200 °C	150 °C	
Preheat: Time (tsmin to tsmax)	60~180 seconds	60~120 seconds	
Temperature to Keep: (TL)	217 °C	183 °C	
Time to Keep: (tL)	60~150 seconds	60~150 seconds	
Peak Temperature (Tp)	260 °C	215 °C	
Time within the peak temperature (tp)	20~40 seconds	10~30 seconds	
Ramp-down Speed	6°C/ second max.	6°C/ second max.	
Time to the peak Temperature	8 minutes max.	6 minutes max.	

DIMENSIONS

Unit: mm

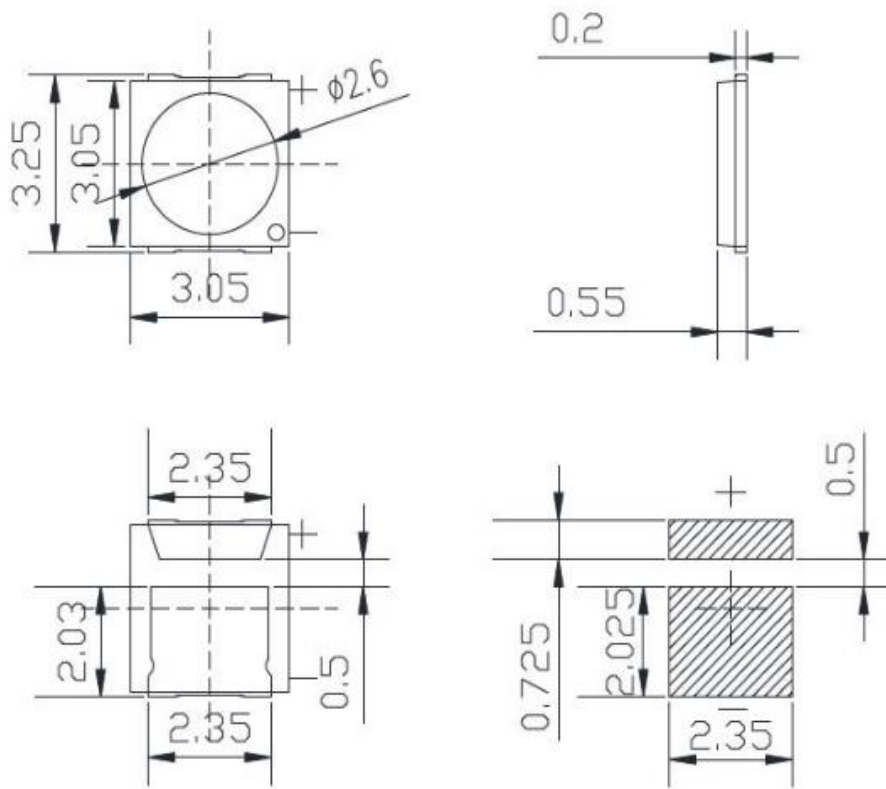

Notes :

*All dimensions are in millimeters.(tolerance:±0.2mm)

*The appearance and specifications of the product may be changed for improvement without notice.

PACKAGING

Tape Specifications (Units : mm)

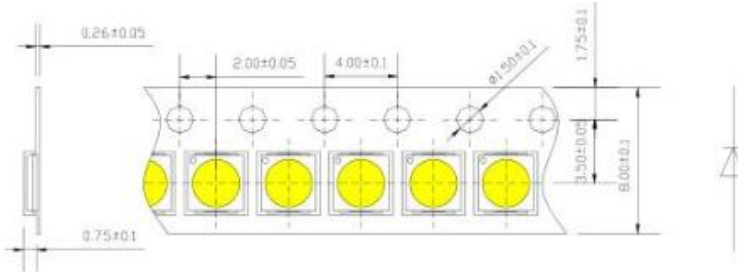

Reel Dimensions

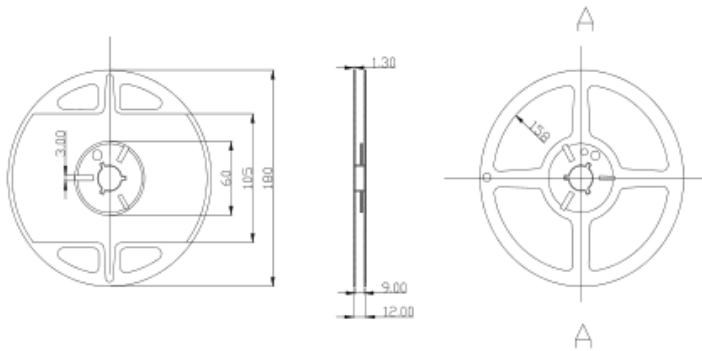

Moisture Resistant Packaging



PRECAUTIONS

1) Storage

Moisture proof and anti-electrostatic package with moisture absorbent material is used, to keep moisture to a minimum.

Before opening the package, the product should be kept at 30°C or less and humidity less than 60% RH, and used within a year.

After opening the package, the product should be stored at 30°C or less and humidity less than 10%RH, and soldered within 24 hours (1day). It is recommended that the product be operated at the workshop condition of 30°C or less and humidity less than 60%RH.

If the moisture absorbent material has faded away or the LEDs have exceeded the storage time, baking treatment should be performed based on the following condition: (70±5)°C for 24 hours.

2) Static Electricity

Static electricity or surge voltage damages the LEDs. Damaged LEDs will show some unusual characteristics such as the forward voltage becoming lower, or the LEDs do not light at the low current, even not light.

All devices, equipment and machinery must be properly grounded. At the same time, it is recommended that wrist bands or anti-electrostatic gloves, anti-electrostatic containers be used when dealing with the LEDs.

3) Vulcanization

LED curing is due to sulfur being in bracket and the +1 price of silver in the chemical reaction generated Ag₂S in the process. It will lead to the capacity of reflecting of silver layer reducing, light color temperature drift and serious decline, seriously affecting the performance of the product. So we should take corresponding measures to avoid vulcanization, such as to avoid using sulphur volatile substances and keeping away from high sulphur content of the material.

4) Safety Advice For Human Eyes

Viewing direct to the light emitting center of the LEDs, especially those of great Luminous Intensity will cause great hazard to human eyes. Please be careful.
