

## 2835 RGB LED Datasheet 6PINS & 4PINS



### Features:

- Slim Size SMD Package: Design Flexibility
- High Lumen Output and High Efficacy
- Stable Performance
- RGB 3 IN 1 Light Color
- Environmental Friendly; ROHS Compliance

### Applications:

- LED Module, Illuminated Advertising
- Tube Light, Panel Light, Ceiling Lamp and other LED Indoor Lights
- Flood Light, High Bay Light, Tunnel Light and other LED Outdoor Lights
- LED Aquarium Light, LED Plant Growing Light..

## TABLE OF CONTENTS

---

PRODUCT NAMING RULES-----	3
CHARACTERISTICS-----	4
RELATIVE SPECTRAL POWER DISTRIBUTION-----	5
TYPICAL CHARACTERISTIC CURVES-----	6
RELIABILITY TESTS-----	7
SOLDERING CONDITIONS-----	8
DIMENSION-----	9
DIMENSION-----	10
PACKAGING-----	11
PRECAUTIONS-----	12
PRECAUTIONS-----	13

## PRODUCT NAMING RULES

---

LKL	XXXX	XX	X	X	X	XX
LKL	Type	Light Color	Chip QTY	Beam Angle	SERIES	PINS
LEKOLED	2835	RGB	1: 1EA	0: 120°/140°	S	6P
		....	2: 2EA			4P
			3: 3EA			
			4: 4EA			
			....			

## CHARACTERISTICS

Light Color	Wavelength (nm)	Forward Voltage	Forward Current	Brightness	Model No.
RGB	R: 620-630	R: 2.0-2.4V	R: 20mA	R: 600-800mcd	LKL-2835RGB30S-6P
	G: 520-530	G: 2.8-3.2V	G: 20mA	G: 1500-1800mcd	LKL-2835RGB30S-4P
	B: 460-470	B: 2.8-3.2V	B: 20mA	B: 400-500mcd	

Absolute Maximum Ratings at T <sub>j</sub> =25°C		
Parameters	Symbol	Maximum Performance
Forward Current	I <sub>F</sub>	20mA
Peak Pulsed Forward Current	I <sub>FP</sub>	45mA
Power Dissipation	P <sub>D</sub>	0.2W
Reverse Voltage	V <sub>R</sub>	5V
Viewing Angle	2θ 1/2	120°
Operating Temperature	T <sub>OPR</sub>	-20 ~ +80°C
Storage Temperature	T <sub>STG</sub>	-40 ~ +80°C
Junction Temperature	T <sub>j</sub>	110°C
Soldering Temperature	T <sub>SLD</sub>	Reflow Soldering: 260°C

Electrical/ Optical Characteristics at T <sub>j</sub> =25°C						
Parameters	Symbol	Min	Type	Max	Unit	Condition
Forward Voltage	V <sub>F</sub>	1.9	3.0	3.4	V	IF=60mA
Reverse Current	I <sub>R</sub>			10	μA	VR=5V
Thermal Resistance	R <sub>th j-sp</sub>		8		°C/W	IF=60mA
Electrostatic Discharge	ESD	1000			V	HBM

## RELATIVE SPECTRAL POWER DISTRIBUTION

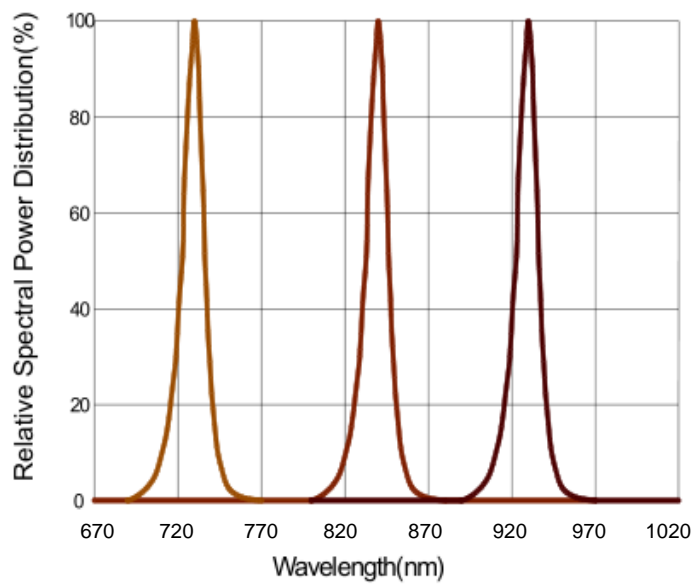
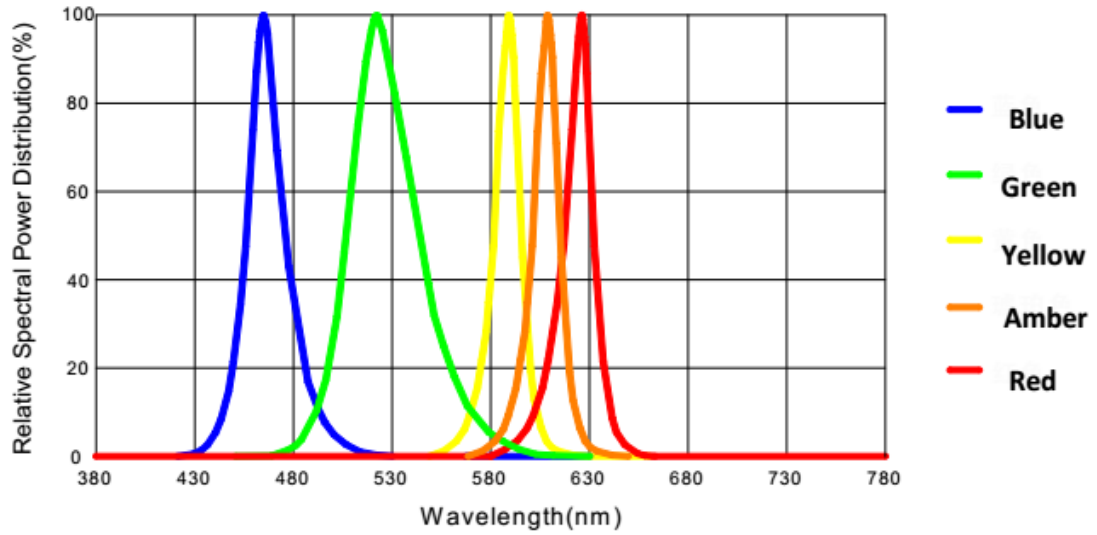

## TYPICAL CHARACTERISTIC CURVES

Specifications ( Tc=25°C)

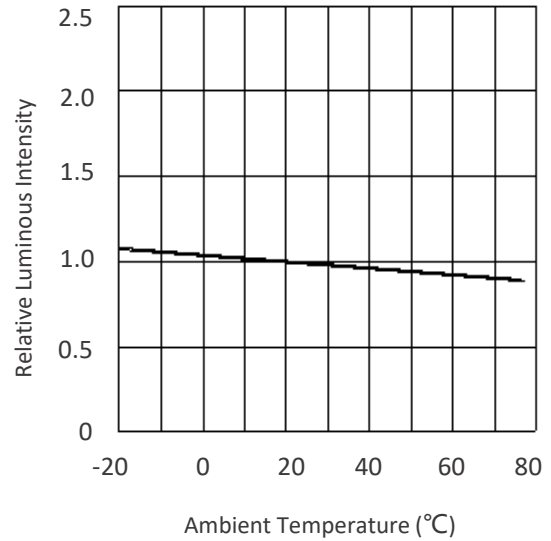
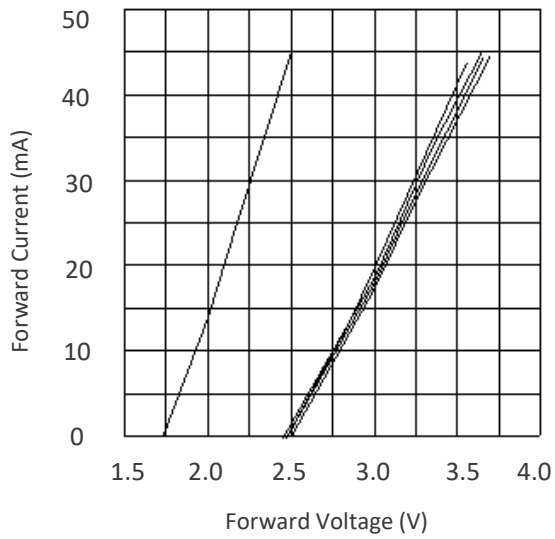
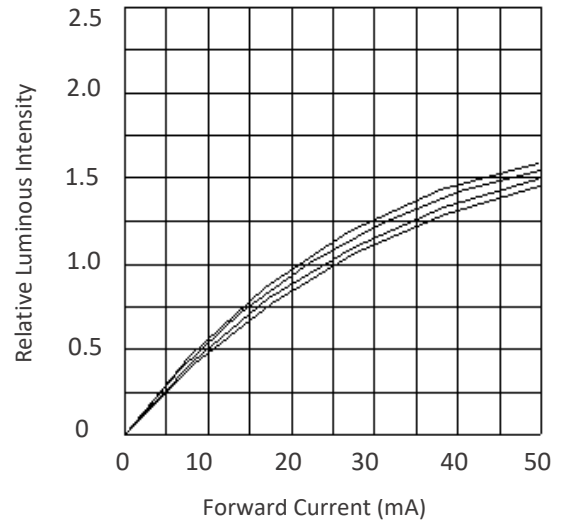
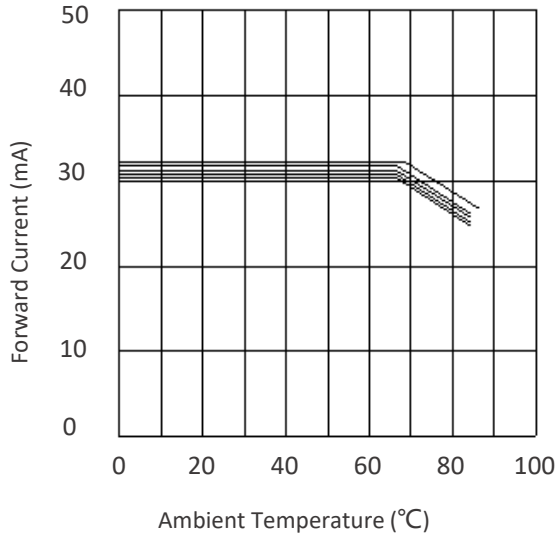

## RELIABILITY TESTS

Test Items	Test Conditions	Note	Sample QTY	Number of Defective
High & Low Temperature Cycle	-25°C 30min ↑↓5min 80°C 30min	100 Cycle	22	0
Thermal Shock	-25°C 30min ↑↓5min 80°C 30min	50 Cycle	22	0
High Humidity Heat Cycle	30°C (<=> 65°C 90%RH 24hrs/1cycle	10 Cycle	22	0
High Temperature Storage	Ta=80°C	6000hrs	22	0/1
High Humidity Heat Storage	Ta=60°C RH=90%	6000hrs	22	0/1
Low Temperature Storage	Ta=-30°C	6000hrs	22	0/1
Aging Test	IF=30mA, Ta=25°C	6000hrs	22	0/1
	IF=30mA, Ta=85°C	6000hrs	22	0/1
High Humidity Heat Aging Test	IF=30mA, Ta=60°C, RH=90%	1000hrs	22	0/1
Low Temperature Aging Test	IF=30mA, Ta=25°C	1000hrs	22	0/1

Criteria for Judging LED Failure (Tc= 25°C)

Items	Symbol	Test Conditions	Criteria for Judging LED Failure
Forward Voltage	VF	IF=30mA	>U x 1.1
Reverse Current	IR	VR=5V	IR</= 10μA
Luminous Intensity	ΦV	IF=30mA	<S x 0.7

U refers to max value; S refers to initial value.

Notes: Judging criteria based on Tc=25°C.

TYPICAL CHARACTERISTIC CURVES

REFLOW SOLDERING PROFILE

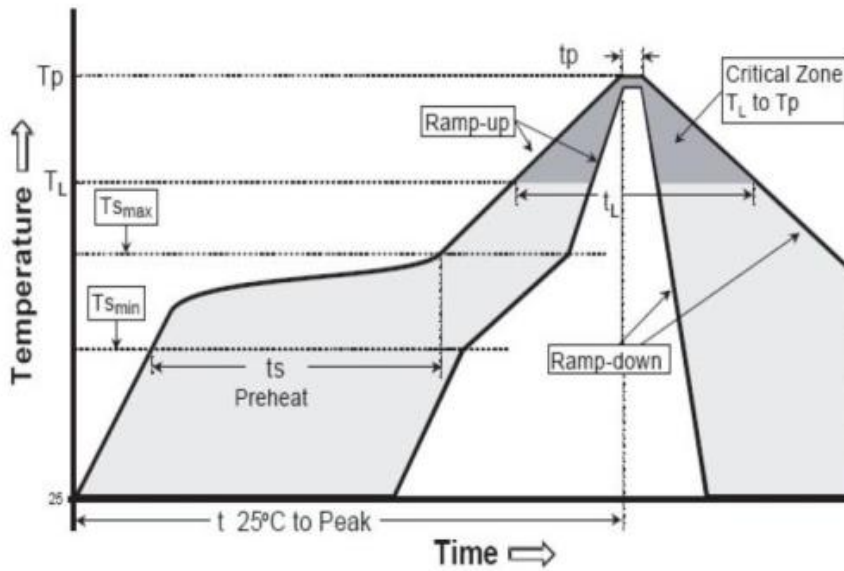

Profile Features	Lead-free solder	Lead solder	Soldering by Manual
Ramp-up Speed(Ts max to Tp)	3 °C/ second max.	3 °C/ second max.	Max. temperature: 350°C  3 seconds/1 time
Preheat: Min. Temperature(Tsmin)	150 °C	100 °C	
Preheat: Max. Temperature(Tsmax)	200 °C	150 °C	
Preheat: Time (tsmin to tsmax)	60~180 seconds	60~120 seconds	
Temperature to Keep: (TL)	217 °C	183 °C	
Time to Keep: (tL)	60~150 seconds	60~150 seconds	
Peak Temperature (Tp)	260 °C	215 °C	
Time within the peak temperature (tp)	20~40 seconds	10~30 seconds	
Ramp-down Speed	6°C/ second max.	6°C/ second max.	
Time to the peak Temperature	8 minutes max.	6 minutes max.	



## DIMENSIONS

Dimension for 6 pins RGB LED

Unit: mm

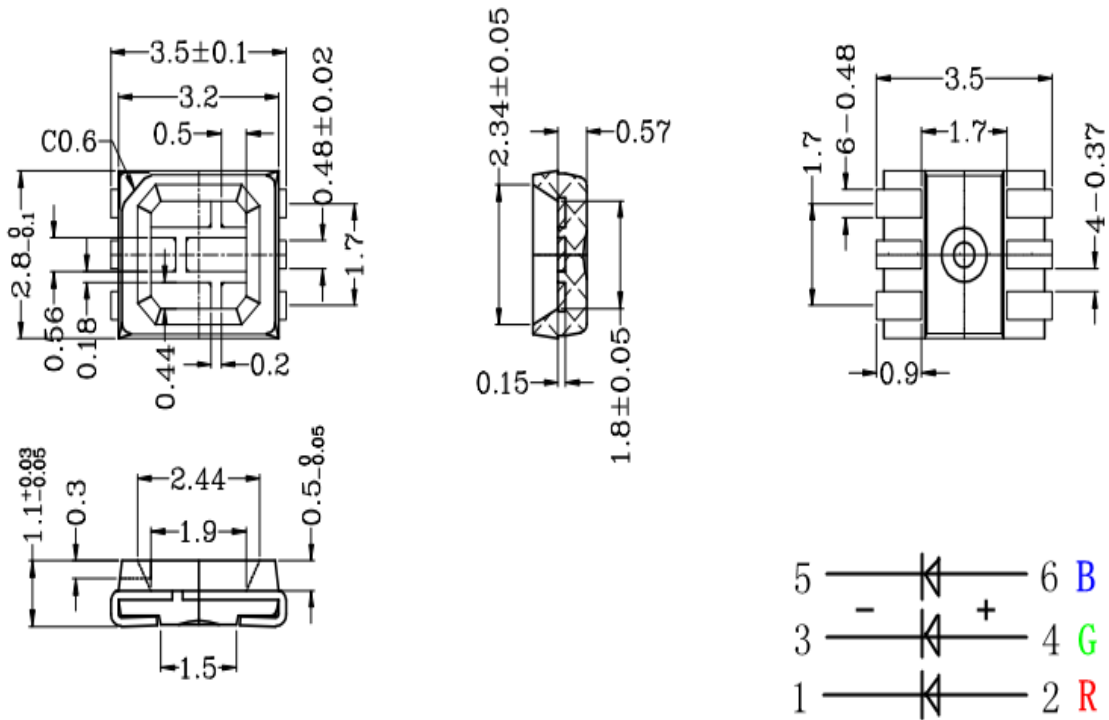

Notes :

\*All dimensions are in millimeters.(tolerance: $\pm 0.1$ mm)

\*The appearance and specifications of the product may be changed for improvement without notice.

## DIMENSIONS

Dimension for 4 pins RGB LED

Unit: mm

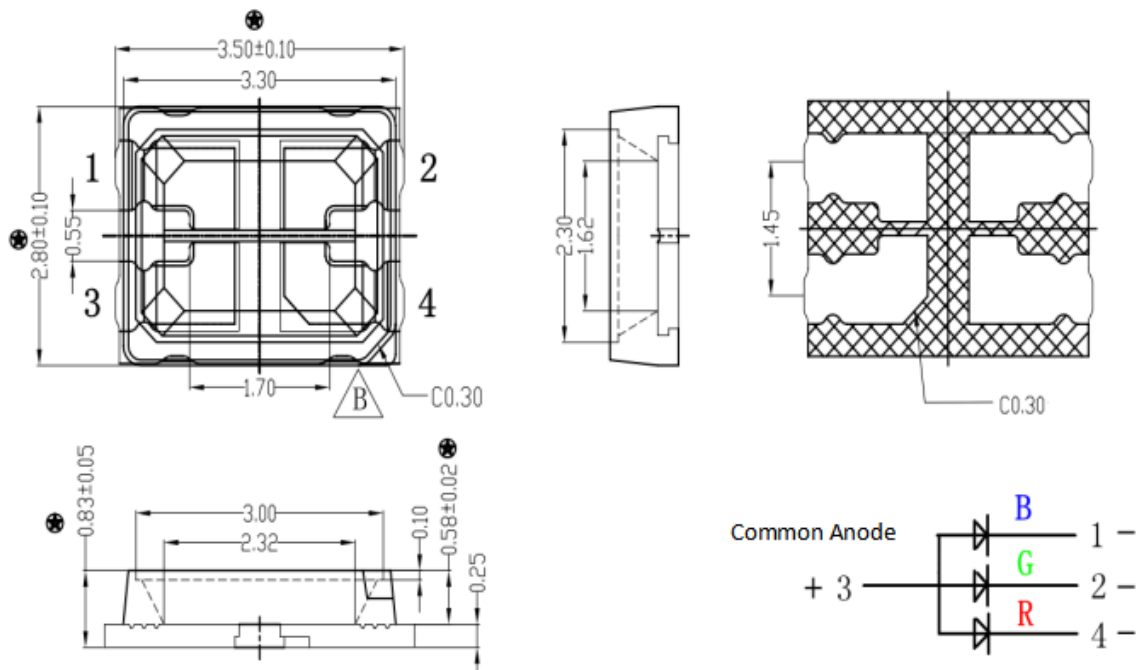

Notes :

\*All dimensions are in millimeters.(tolerance: $\pm 0.1$ mm)

\*The appearance and specifications of the product may be changed for improvement without notice.

## PACKAGING

Tape Specifications (Units : mm)

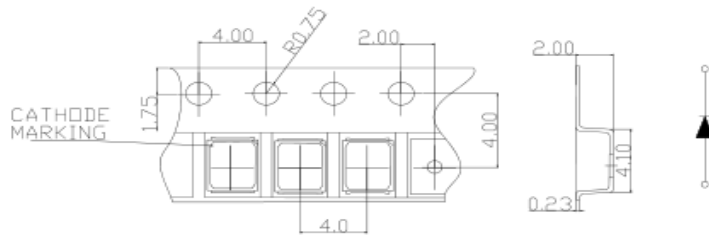

Reel Dimensions

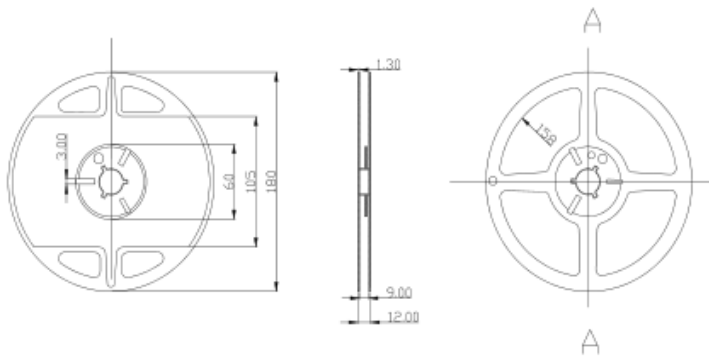

Moisture Resistant Packaging

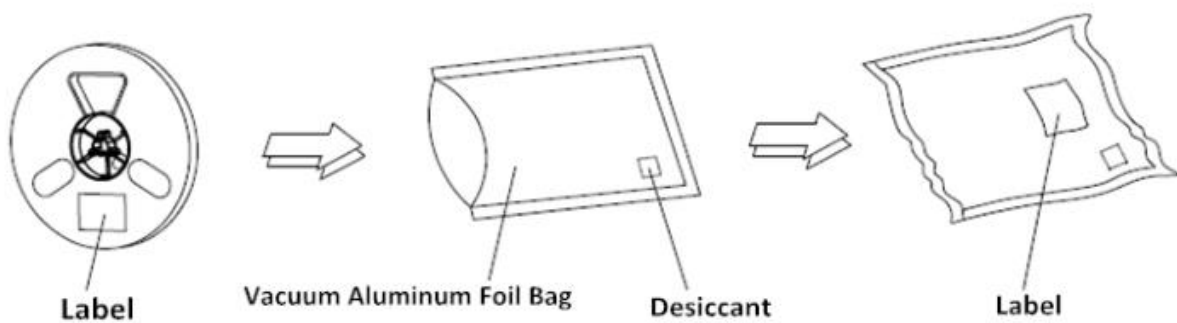

## PRECAUTIONS

### Storage

1. Moisture proof and anti-electrostatic package with moisture absorbent material is used, to keep moisture to a minimum.
2. Before opening the package, the product should be kept at 30°C or less and humidity less than 60% RH, and be used within a year.
3. After opening the package, the product should be stored at 30°C or less and humidity less than 10%RH, and be soldered within 24 hrs (1day). It is recommended that the product be operated at the workshop condition of 30°C or less and humidity less than 60%RH.
4. If the moisture absorbent material has faded away or the LEDs have exceeded the storage time, baking treatment should be performed based on the following condition: (80±5)°C for 24 hours.

### Static Electricity

1. Static electricity or surge voltage damages the LEDs. Damaged LEDs will show some unusual characteristic such as the forward voltage becomes lower, or the LEDs do not light at the low current. even not light.
2. All devices, equipment and machinery must be properly grounded. At the same time, it is recommended that wrist bands or anti-electrostatic gloves, anti-electrostatic containers be used when dealing with the LEDs.

### Vulcanization

LED curing is due to sulfur being in bracket and the +1 price of silver in the chemical reaction generated Ag<sub>2</sub>S in the process. It will lead to the capacity of reflecting of silver layer reducing, light color temperature drift and serious decline, seriously affecting the performance of the product. So we should take corresponding measures to avoid vulcanization, such as to avoid using sulphur volatile substances and keeping away from high sulphur content of the material.

### Design Consideration

1. In designing a circuit, the current through each LED must not exceed the absolute maximum rating specified for each LED. In the meanwhile, resistors for protection should be applied, otherwise slight voltage shift will cause big current change, burn out may happen.
2. It is recommended to use Circuit A which regulates the current flowing through each LED rather than Circuit B. When driving LEDs with a constant voltage in Circuit B, the current through the LEDs may vary due to the variation in Forward Voltage (VF) of the LEDs. In the worst case, some LED may be subjected to stresses in excess of the Absolute Maximum Rating.

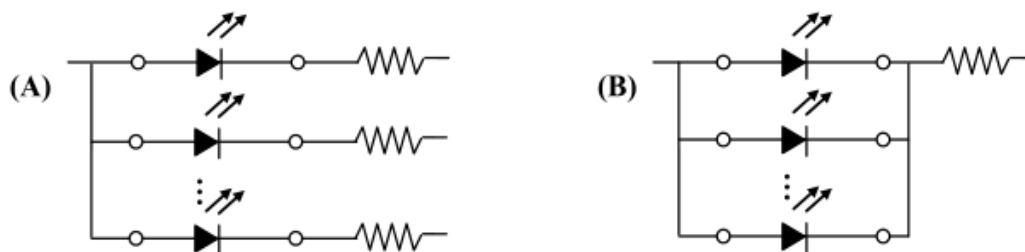

3. Thermal Design is paramount importance because heat generation may result in the Characteristics decline, such as brightness decreased, Color changed and so on. Please consider the heat generation of the LEDs when making the system design.

## PRECAUTIONS

---

### Safety Advice For Human Eyes

Viewing direct to the light emitting center of the LEDs, especially those of great Luminous Intensity will cause great hazard to human eyes. Please be careful.

### The safe temperature for LEDs working

The high temperature will make the LEDs' Luminous Intensity decreased radically, if LEDs worked in hoteyes. Please be careful. environment for a long time, they will be disabled easily. When LEDs are working in a closed array, we suggest that the LEDs' surface temperature should be lower than 55°C and the legs' temperature should be lower than 75°C.

### Others

1. When handling the product, touching the encapsulant with bare hands will not only contaminate its surface, but also affect on its optical characteristics. Excessive force to the encapsulant might result in catastrophic failure of the LEDs due to Die breakage or wire deformation. For this reason, please do not put excessive stress on LEDs, especially when the LEDs are heated such as during Reflow Soldering.

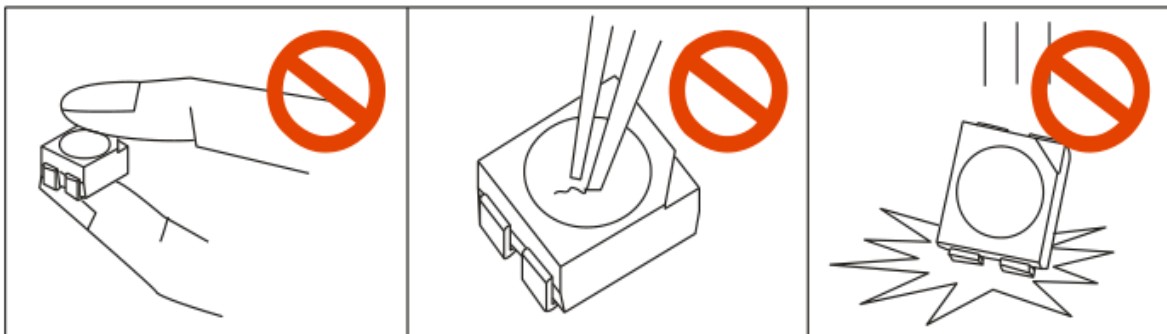

2. The epoxy resin of encapsulant is fragile, so please avoid scratch or friction over the epoxy resin surface. While handling the product with tweezers, do not hold by the epoxy resin, be careful.