

2835 Full Spectrum Datasheet



Features:

- Slim Size SMD Package: Design Flexibility
- High Lumen Output and High Efficacy
- Stable Performance & Great CCT Unity
- Full Spectrum 380-850nm
- High Forward Voltage 9V, 18V, 36V Available
- Environmental Friendly; ROHS Compliance
- Customized Service Available

Applications:

- LED Module, Illuminated Advertising
 - Tube Light, Panel Light, Ceiling Lamp and other LED Indoor Lights
 - Flood Light, High Bay Light, Tunnel Light and other LED Outdoor Lights
 - LED Aquarium Light, LED Plant Growing Light..
-

TABLE OF CONTENTS



PRODUCT NAMING RULES-----3

CHARACTERISTICS-----4

LUMINOUS FLUX CHARACTERISTIC-----5

CHARACTERISTIC CURVES-----6

CHARACTERISTIC CURVES-----7

FULL SPECTRUM CURVES-----8-17

RELIABILITY TESTS-----18

SOLDERING CONDITIONS-----19

DIMENSION-----20

PACKAGING-----21

PRECAUTIONS-----22

PRECAUTIONS-----23

PRODUCT NAMING RULES

LKL	XXXX	FSXX	X	X	XXX
LKL	Type	Color	Chip QTY	Beam Angle	Brightness
LEKOLED	2835	FS01: Full Spectrum 1	1: 1EA	0: 120°/140°	15: 15-18LM
		FS03: Full Spectrum 3	2: 2EA		30: 30-32LM
		FS11: Full Spectrum 11	3: 3EA	
				

CHARACTERISTICS

Parameter	Unit	Min	Typical	Max
Power Dissipation 1	mW		200	
Power Dissipation 2	mW		504	
Forward Current 1	mA		60	
Forward Current 2	mA		150	
Forward Voltage	V	2,8		3,4
Color Rendering Index	Ra		90	
Beam Angle 2θ1/2	deg.		120	
Reverse Current	uA			10
Reverse Voltage	V			5
Operating Temperature Top	°C	-40		+60
Storage Temperature Tst	°C	-40		+85
Testing Point Tc	°C			55
Junction Temperature Tj	°C			120
Reverse Current (Vr=5V) Ir	uA			5
Related thermal resistance Rj-c	°C/W		8	
ESD (HBM)	V			2000
Reflow Soldering (Lead-Free) ST	°C			260

LUMINOUS FLUX CHARACTERISTIC

Specifications (IF=60mA, Tc=25°C)

Light Color	Color Temperature (K)	CRI	0.2W, 3V @60mA	Model No.
			LM	
Full Spectrum 01	1200-1300K	/	30-32	LKL-2835FS011030
Full Spectrum 03	2900-3000K	90	15-18	LKL-2835FS031015
Full Spectrum 04	6800-7000K	90	15-18	LKL-2835FS041015
Full Spectrum 05	2900-3000K	90	15-18	LKL-2835FS031015
Full Spectrum 07	1700-1800K	/	30-32	LKL-2835FS071030
Full Spectrum 09	1200-1300K	/	30-32	LKL-2835FS091030
Full Spectrum 11	4700-4900K	/	30-32	LKL-2835FS111030
Full Spectrum 13	4200-4400K	90	15-18	LKL-2835FS131015
Full Spectrum 15	2000-2200K	/	30-32	LKL-2835FS151030
Full Spectrum 16	100000K	/	30-32	LKL-2835FS161030

Specifications (IF=150mA, Tc=25°C)

Light Color	Color Temperature (K)	CRI	0.5W, 3V @150mA	Model No.
			LM	
Full Spectrum 01	1200-1300K	/	50-60	LKL-2835FS012050
Full Spectrum 03	2900-3000K	90	30-40	LKL-2835FS032030
Full Spectrum 04	6800-7000K	90	30-40	LKL-2835FS042030
Full Spectrum 05	2900-3000K	90	30-40	LKL-2835FS032030
Full Spectrum 07	1700-1800K	/	50-60	LKL-2835FS072050
Full Spectrum 09	1200-1300K	/	50-60	LKL-2835FS092050
Full Spectrum 11	4700-4900K	/	50-60	LKL-2835FS112050
Full Spectrum 13	4200-4400K	90	30-40	LKL-2835FS132030
Full Spectrum 15	2000-2200K	/	50-60	LKL-2835FS152050
Full Spectrum 16	100000K	/	50-60	LKL-2835FS162050

TYPICAL CHARACTERISTIC CURVES

IF=60mA

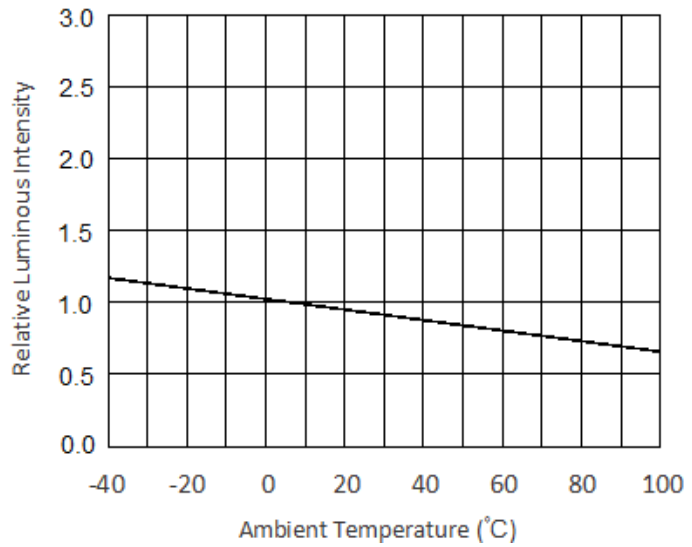
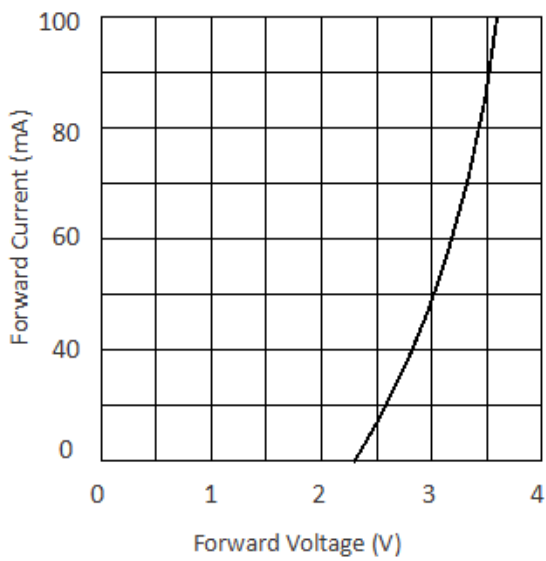
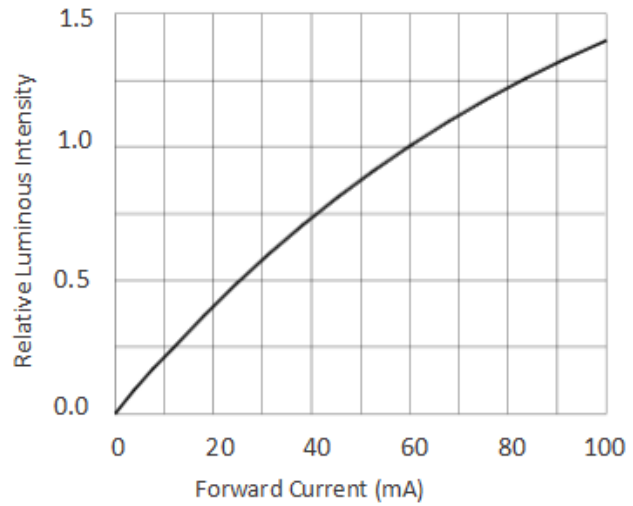
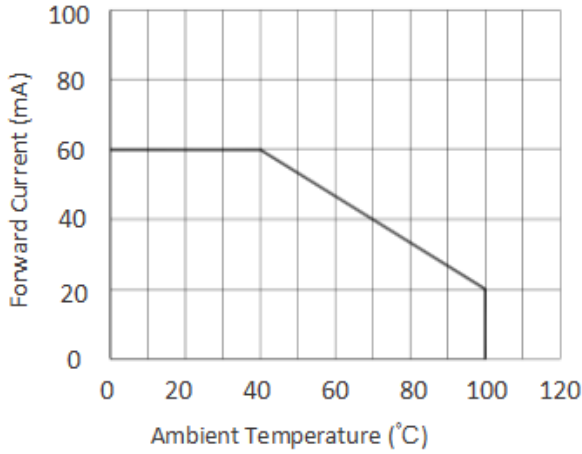

TYPICAL CHARACTERISTIC CURVES

IF=150mA

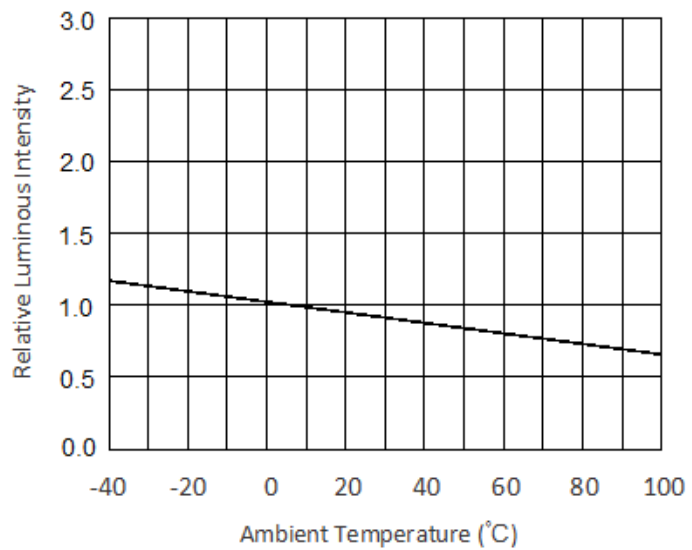
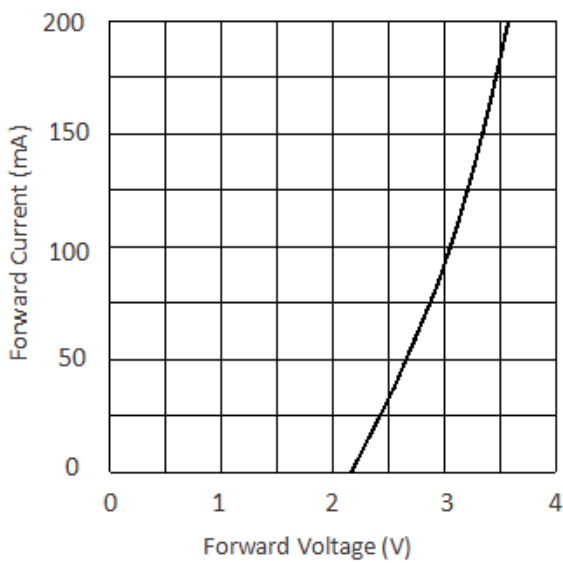
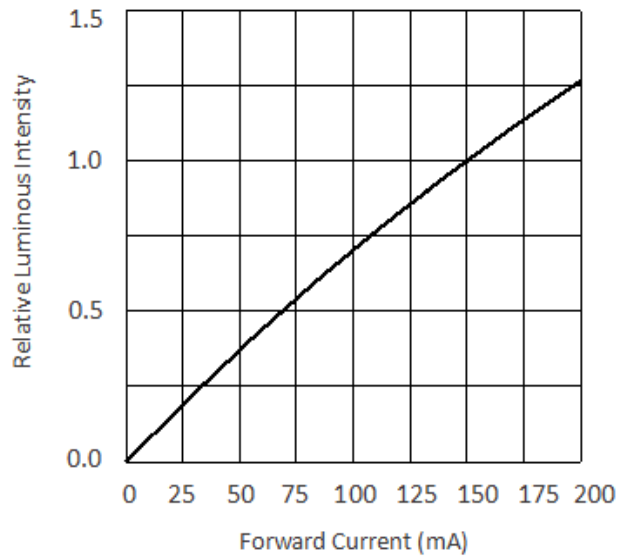
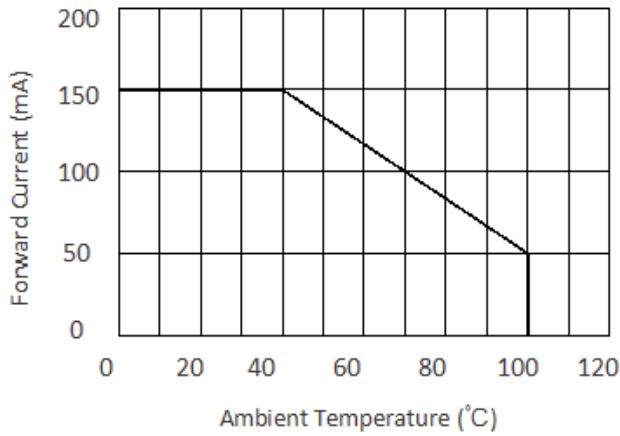

FULL SPECTRUM CURVES

NO. 1

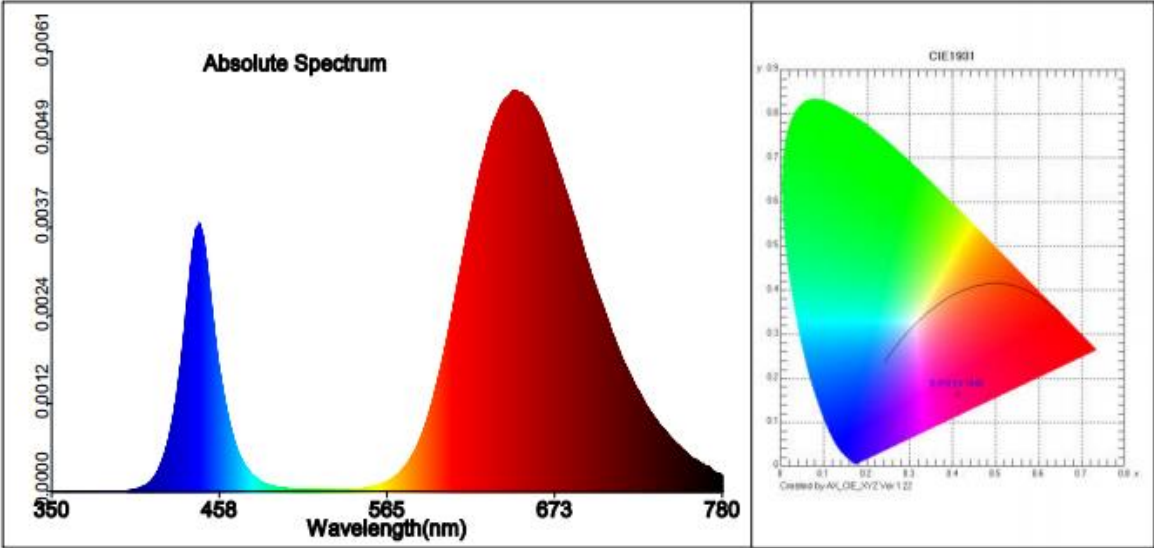

Test parameter:

E= 49.0 lx	E(fc)=4.54948 fc		
CIE x= 0.4103	CIE y= 0.1640	CIE u'=0.3957	CIE v'=0.3559
Tc=1211 K	Lp=661.0 nm	HW=94.3 nm	Ld=610.2 nm
Pur=55.8 %	Ratio_R=78.6 %	Ratio_G=13.8 %	Ratio_B=7.6 %
Duv=0.12108			
Ra=-17.4	R1= 57	R2=-18	R3=-98
R4= 16	R5= 12	R6=-121	R7=-31
R8= 44	R9= 54	R10=-155	R11= 40
R12=-515	R13= 13	R14= -4	R15= 51
SDCM= 0.2()			
White Class:OUT			
E1=0.57817 W/m2	E2=0.73919 W/m2	PPFD=2.9661 μmol/(m·s)	
Ech-A=0.15406 W/m2	Ech-B=0.1342 W/m2	Ef=0.16144 W/m2	
Eb=0.11689 W/m2	Ey=0.013469 W/m2	Er=0.44791 W/m2	
Ep=0.52529 Wphyto/m2	Erb_Ratio=3.8317		
PPFDf=9.4289E-001 μmol/(m2·s)			

FULL SPECTRUM CURVES

NO. 3

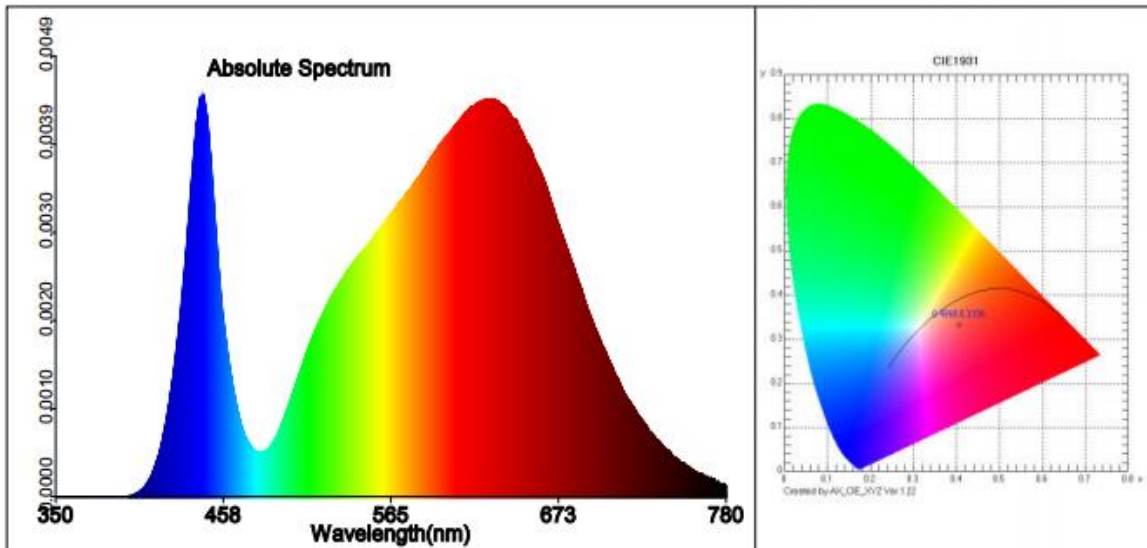

Test parameter:

E= 220.7 lx

E(fc)=20.5151 fc

CIE x= 0.4068

CIE y= 0.3336

CIE u'=0.2629

CIE v'=0.4851

Tc=2910 K

Lp=449.0 nm

HW=26.2 nm

Ld=609.8 nm

Pur=22.1 %

Ratio_R=26.4 %

Ratio_G=71.0 %

Ratio_B=2.7 %

Duv=-0.02696

Ra=92.1

R1= 97

R2= 95

R3= 92

R4= 87

R5= 95

R6= 92

R7= 88

R8= 91

R9= 92

R10= 90

R11= 85

R12= 89

R13= 96

R14= 94

R15= 94

SDCM= 0.3()

White Class:OUT

E1=0.86312 W/m2

E2=0.96281 W/m2

PPFD=4.2011 $\mu\text{mol}/(\text{m}\cdot\text{s})$

Ech-A=0.12159 W/m2

Ech-B=0.13853 W/m2

Ef=0.099952 W/m2

Eb=0.16281 W/m2

Ey=0.27285 W/m2

Er=0.42796 W/m2

Ep=0.77237 Wphyto/m2

Erb_Ratio=2.6286

PPFDf=5.8502E-001 $\mu\text{mol}/(\text{m}^2\cdot\text{s})$

FULL SPECTRUM CURVES

NO. 4

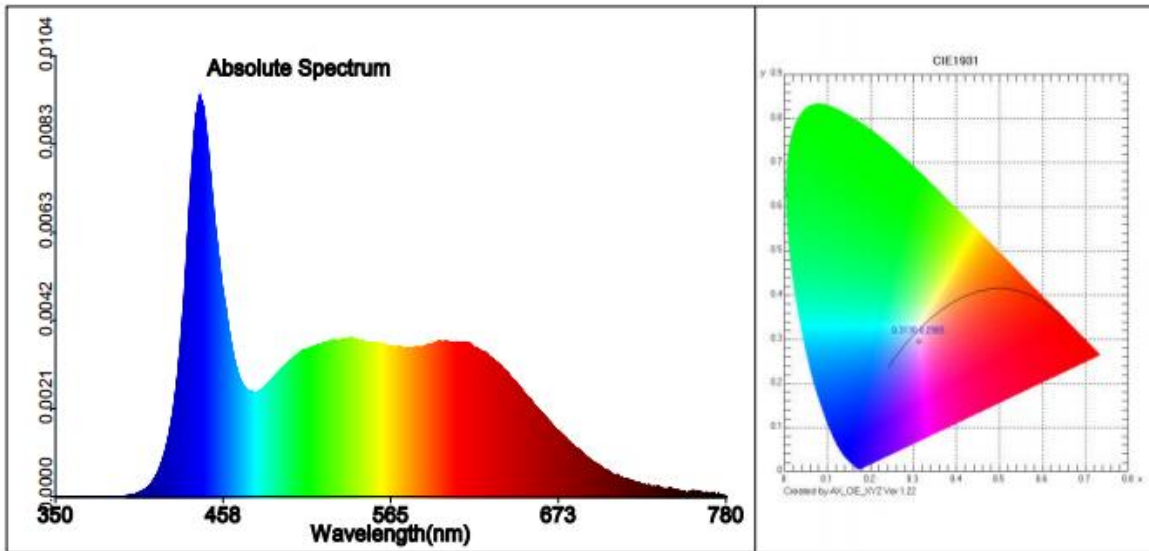

Test parameter:

E= 284.1 lx

E(fc)=26.4054 fc

CIE x= 0.3130

CIE y= 0.2965

CIE u'=0.2110

CIE v'=0.4499

Tc=6816 K

Lp=447.0 nm

HW=26.5 nm

Ld=448.4 nm

Pur=11.6 %

Ratio_R=17.4 %

Ratio_G=76.2 %

Ratio_B=6.4 %

Duv=-0.01470

Ra=90.3

R1= 90

R2= 94

R3= 86

R4= 88

R5= 92

R6= 89

R7= 93

R8= 90

R9= 73

R10= 89

R11= 86

R12= 79

R13= 91

R14= 91

R15= 86

SDCM= 0.3()

White Class:OUT

E1=1.0696 W/m2

E2=1.1077 W/m2

PPFD=4.858 $\mu\text{mol}/(\text{m}\cdot\text{s})$

Ech-A=0.078194 W/m2

Ech-B=0.11615 W/m2

Ef=0.038201 W/m2

Eb=0.37545 W/m2

Ey=0.38903 W/m2

Er=0.30584 W/m2

Ep=0.90075 Wphyto/m2

Erb_Ratio=0.8146

PPFDf=2.2503E-001 $\mu\text{mol}/(\text{m}^2\cdot\text{s})$

FULL SPECTRUM CURVES

NO. 5

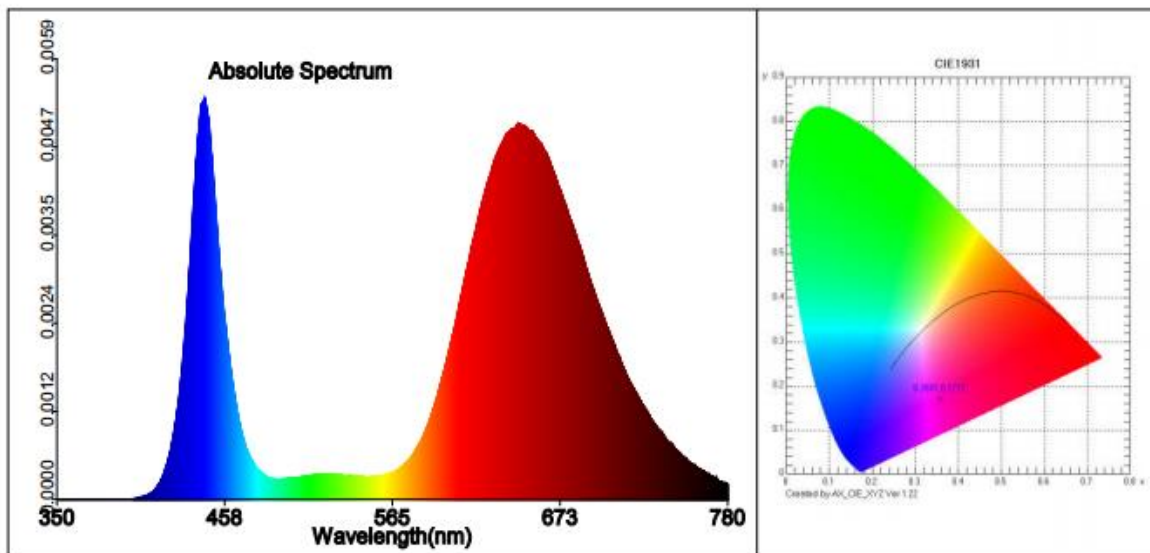

Test parameter:

E= 66.7 lx

E(fc)=6.19713 fc

CIE x= 0.3581

CIE y= 0.1712

CIE u'=0.3302

CIE v'=0.3551

Tc=1768 K

Lp=449.0 nm

HW=23.7 nm

Ld=610.2 nm

Pur=49.2 %

Ratio_R=57.2 %

Ratio_G=34.2 %

Ratio_B=8.6 %

Duv=-0.12360

Ra=2.0

R1= 9

R2=-18

R3=-19

R4= 75

R5=-25

R6=-91

R7= 31

R8= 53

R9=-65

R10=-145

R11= 46

R12=-334

R13=-21

R14= 41

R15= -9

SDCM= 0.2()

White Class:OUT

E1=0.62799 W/m²

E2=0.77204 W/m²

PPFD=3.1203 μmol/(m·s)

Ech-A=0.13376 W/m²

Ech-B=0.11571 W/m²

Ef=0.14442 W/m²

Eb=0.16913 W/m²

Ey=0.042269 W/m²

Er=0.41674 W/m²

Ep=0.55871 Wphyto/m²

Erb_Ratio=2.4641

PPFDf=8.4310E-001 μmol/(m²·s)

FULL SPECTRUM CURVES

NO. 7

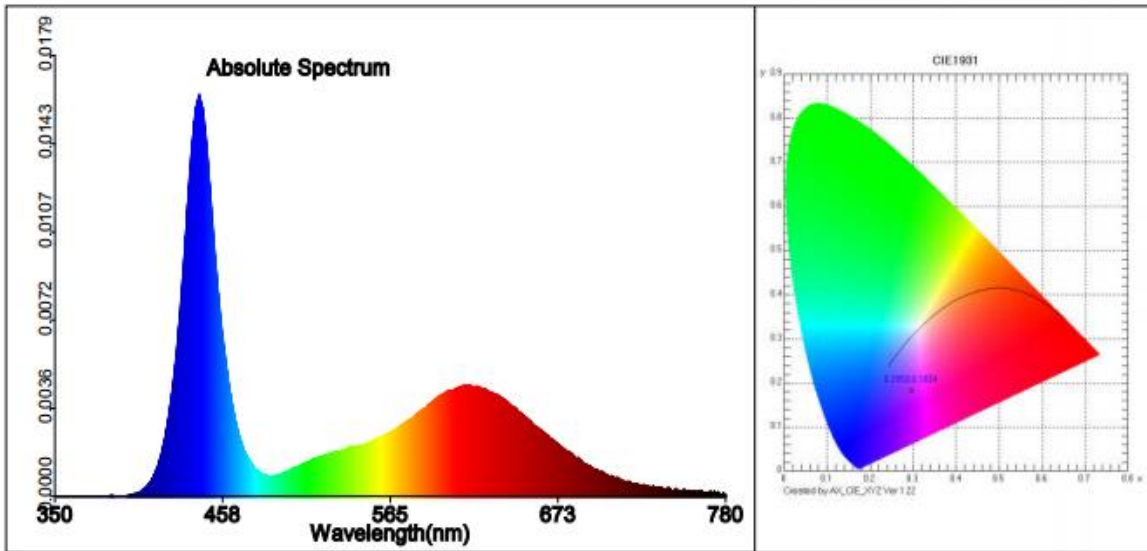

Test parameter:

E= 202.8 lx	E(fc)=18.8464 fc		
CIE x= 0.2958	CIE y= 0.1834	CIE u'=0.2567	CIE v'=0.3581
Tc=100000 K	Lp=447.0 nm	HW=24.9 nm	Ld=380.0 nm
Pur=42.4 %	Ratio_R=28.6 %	Ratio_G=63.2 %	Ratio_B=8.2 %
Duv=-0.08083			
Ra=41.2	R1= 15	R2= 52	R3= 56
R4= 34	R5= 33	R6= 48	R7= 80
R8= 11	R9=-191	R10= 30	R11= 23
R12= 52	R13= 21	R14= 67	R15=-17
SDCM= 0.2()			
White Class:OUT			
E1=1.144 W/m ²	E2=1.2004 W/m ²	PPFD=5.1242 μmol/(m ² ·s)	
Ech-A=0.094375 W/m ²	Ech-B=0.12661 W/m ²	Ef=0.056532 W/m ²	
Eb=0.53494 W/m ²	Ey=0.22667 W/m ²	Er=0.38287 W/m ²	
Ep=0.9637 Wphyto/m ²	Erb_Ratio=0.71572		
PPFDf=3.2785E-001 μmol/(m ² ·s)			

FULL SPECTRUM CURVES

NO. 9

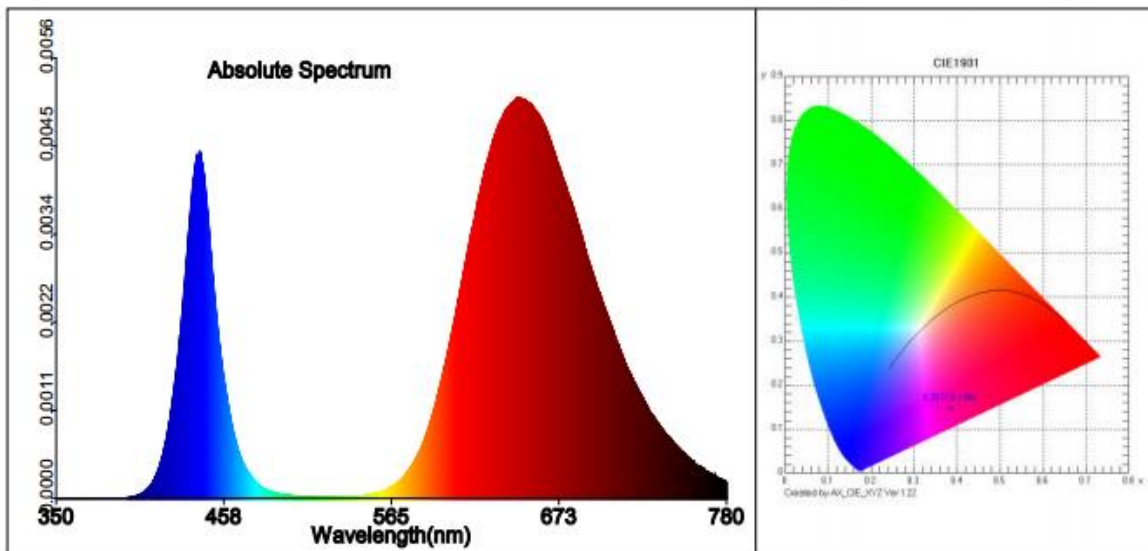

Test parameter:

E= 47.9 lx

$E(fc)=4.45347 fc$

CIE x= 0.3837

CIE y= 0.1486

CIE u'=0.3821

CIE v'=0.3331

Tc=1289 K

Lp=660.0 nm

HW=95.7 nm

Ld=610.2 nm

Pur=57.5 %

Ratio_R=77.0 %

Ratio_G=15.1 %

Ratio_B=8.0 %

Duv=0.13714

Ra=-24.6

R1= 54

R2=-27

R3=-110

R4= 4

R5= 10

R6=-132

R7=-40

R8= 44

R9= 45

R10=-172

R11= 27

R12=-516

R13= 6

R14=-11

R15= 40

SDCM= 0.1()

White Class:OUT

E1=0.56991 W/m²

E2=0.71745 W/m²

PPFD=2.8754 $\mu\text{mol}/(\text{m}\cdot\text{s})$

Ech-A=0.13219 W/m²

Ech-B=0.11071 W/m²

Ef=0.14791 W/m²

Eb=0.1394 W/m²

Ey=0.014353 W/m²

Er=0.41626 W/m²

Ep=0.51337 Wphyto/m²

Erb_Ratio=2.986

PPFDf=8.6331E-001 $\mu\text{mol}/(\text{m}^2\cdot\text{s})$

FULL SPECTRUM CURVES

NO. 11

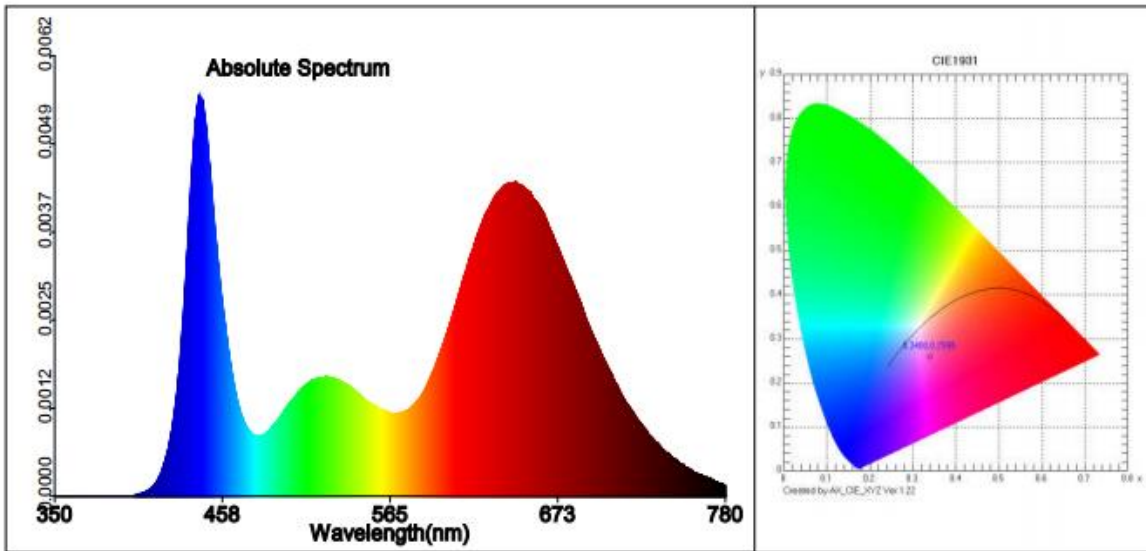

Test parameter:

E= 132.1 lx	E(fc)=12.2804 fc		
CIE x= 0.3400	CIE y= 0.2595	CIE u'=0.2503	CIE v'=0.4298
Tc=4710 K	Lp=447.0 nm	HW=24.7 nm	Ld=610.2 nm
Pur=22.3 %	Ratio_R=29.6 %	Ratio_G=64.2 %	Ratio_B=6.2 %
Duv=-0.05329			
Ra=45.8	R1= 30	R2= 62	R3= 79
R4= 35	R5= 35	R6= 60	R7= 69
R8= -4	R9=-145	R10= 31	R11= 25
R12= 43	R13= 35	R14= 83	R15= 2
SDCM= 0.3()			
White Class:OUT			
E1=0.72767 W/m2	E2=0.84431 W/m2	PPFD=3.5175 μmol/(m·s)	
Ech-A=0.11241 W/m2	Ech-B=0.10372 W/m2	Ef=0.11696 W/m2	
Eb=0.19437 W/m2	Ey=0.15306 W/m2	Er=0.38052 W/m2	
Ep=0.63509 Wphyto/m2	Erb_Ratio=1.9577		
PPFDf=6.8427E-001 μmol/(m2·s)			

FULL SPECTRUM CURVES

NO. 13

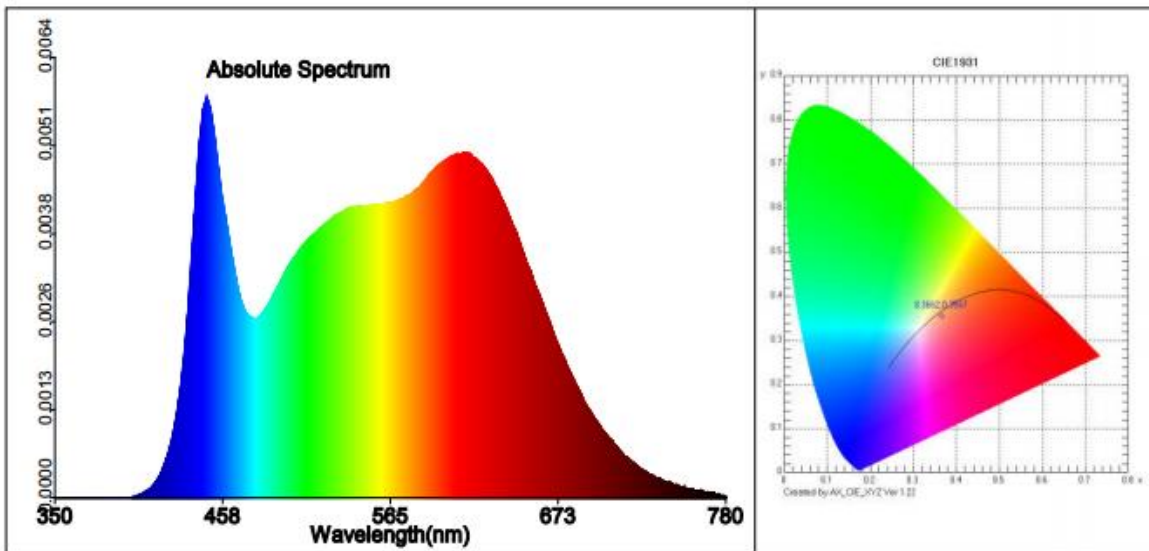

Test parameter:

E= 333.1 lx

E(fc)=30.9572 fc

CIE x= 0.3662

CIE y= 0.3567

CIE u'=0.2237

CIE v'=0.4903

Tc=4277 K

Lp=452.0 nm

HW=34.5 nm

Ld=582.3 nm

Pur=16.9 %

Ratio_R=20.1 %

Ratio_G=74.9 %

Ratio_B=5.0 %

Duv=-0.00526

Ra=97.3

R1= 98

R2= 98

R3= 97

R4= 99

R5= 98

R6= 95

R7= 97

R8= 97

R9= 95

R10= 98

R11= 97

R12= 79

R13= 98

R14= 98

R15= 97

SDCM= 0.4()

White Class:OUT

E1=1.1474 W/m2

E2=1.2016 W/m2

PPFD=5.4105 $\mu\text{mol}/(\text{m}\cdot\text{s})$

Ech-A=0.094271 W/m2

Ech-B=0.12282 W/m2

Ef=0.054369 W/m2

Eb=0.27442 W/m2

Ey=0.44644 W/m2

Er=0.42738 W/m2

Ep=0.99299 Wphyto/m2

Erb_Ratio=1.5574

PPFDf=3.2254E-001 $\mu\text{mol}/(\text{m}^2\cdot\text{s})$

FULL SPECTRUM CURVES

NO. 15

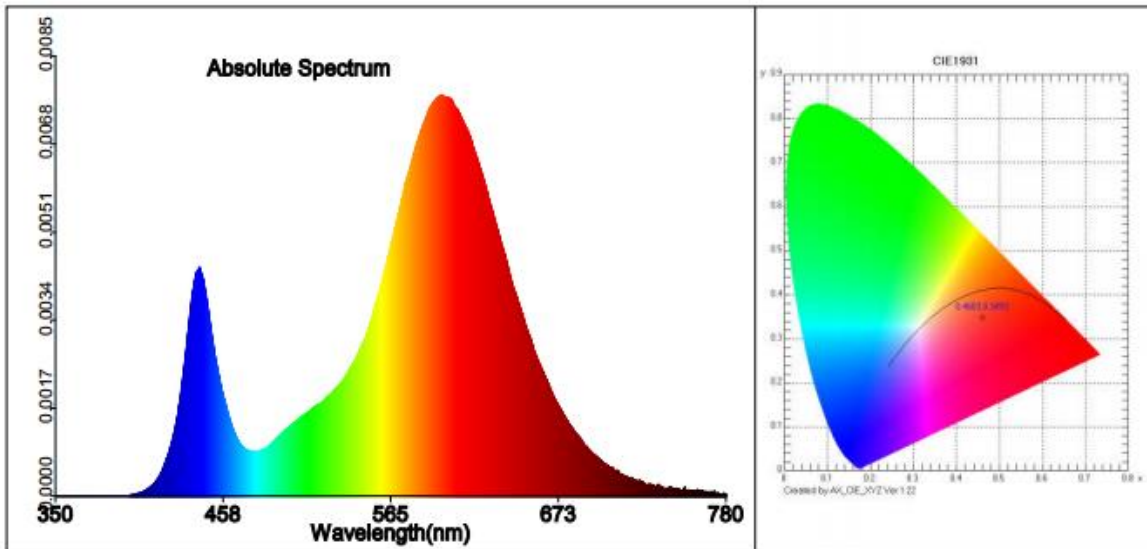

Test parameter:

E= 307.9 lx

E(fc)=28.6185 fc

CIE x= 0.4603

CIE y= 0.3493

CIE u'=0.2936

CIE v'=0.5013

Tc=2197 K

Lp=609.0 nm

HW=92.7 nm

Ld=600.4 nm

Pur=42.9 %

Ratio_R=31.5 %

Ratio_G=66.2 %

Ratio_B=2.3 %

Duv=-0.02341

Ra=75.2

R1= 80

R2= 96

R3= 79

R4= 68

R5= 82

R6= 90

R7= 65

R8= 43

R9= 0

R10= 95

R11= 67

R12= 82

R13= 85

R14= 89

R15= 74

SDCM= 0.3()

White Class:OUT

E1=1.048 W/m²

E2=1.0841 W/m²

PPFD=5.1078 μmol/(m²·s)

Ech-A=0.091626 W/m²

Ech-B=0.14551 W/m²

Ef=0.0363 W/m²

Eb=0.1642 W/m²

Ey=0.36369 W/m²

Er=0.52102 W/m²

Ep=0.95354 Wphyto/m²

Erb_Ratio=3.1731

PPFDf=2.1342E-001 μmol/(m²·s)

FULL SPECTRUM CURVES

NO. 16

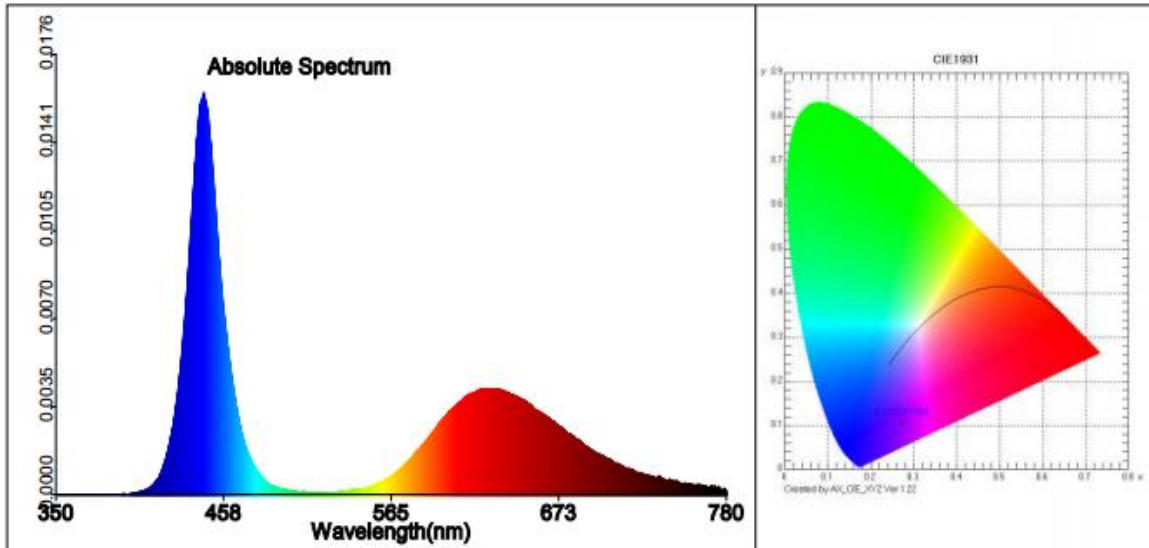

Test parameter:

E= 92.5 lx	E(fc)=8.59386 fc		
CIE x= 0.2735	CIE y= 0.1059	CIE u'=0.2937	CIE v'=0.2560
Tc=100000 K	Lp=449.0 nm	HW=23.9 nm	Ld=380.0 nm
Pur=64.4 %	Ratio_R=51.8 %	Ratio_G=30.8 %	Ratio_B=17.4 %
Duv=-0.14787			
Ra=-67.8	R1=-85	R2=-111	R3=-114
R4=-11	R5=-66	R6=-110	R7= 5
R8=-50	R9=-455	R10=-357	R11=-38
R12=-188	R13=-113	R14= 3	R15=-166
SDCM= 0.1()			
White Class:OUT			
E1=0.92845 W/m2	E2=1.0241 W/m2	PPFD=4.1796 μmol/(m·s)	
Ech-A=0.09374 W/m2	Ech-B=0.10334 W/m2	Ef=0.095869 W/m2	
Eb=0.4968 W/m2	Ey=0.054004 W/m2	Er=0.37792 W/m2	
Ep=0.77968 Wphyto/m2	Erb_Ratio=0.76071		
PPFDf=5.5020E-001 μmol/(m2·s)			

RELIABILITY TESTS

Test Items	Test Conditions	Sample QTY	Ac/Re
Aging Test	IF=60-150mA, Ta=25°C x6000hrs	22	0/1
	IF=60-150mA, Ta=85°C x6000hrs	22	0/1
High Temperature Storage	100°C x1000hrs	22	0/1
Low Temperature Storage	-40°C x1000hrs	22	0/1
High Temp & Humidity	IF=60-150mA, 85°C, 85% RH for 6000hrs	22	0/1
Temperature Shock	-40°Cx30 min & +100°Cx30 min, 100cycle	22	0/1
ESD(HBM)	2000V HBM/ 1 Time	10	0/1

Criteria for Judging LED Failure (Tc= 25°C)

Items	Symbol	Test Conditions	Criteria for Judging LED Failure
Forward Voltage	VF	IF=60-150mA	>U x 1.1
Reverse Current	IR	VR=5V	IR>= 10μA
Lumen	ΦV	IF=60-150mA	<S x 0.7

U refers to max value; S refers to initial value.

Notes: Judging criteria based on Tc=25°C.

TYPICAL CHARACTERISTIC CURVES

REFLOW SOLDERING PROFILE

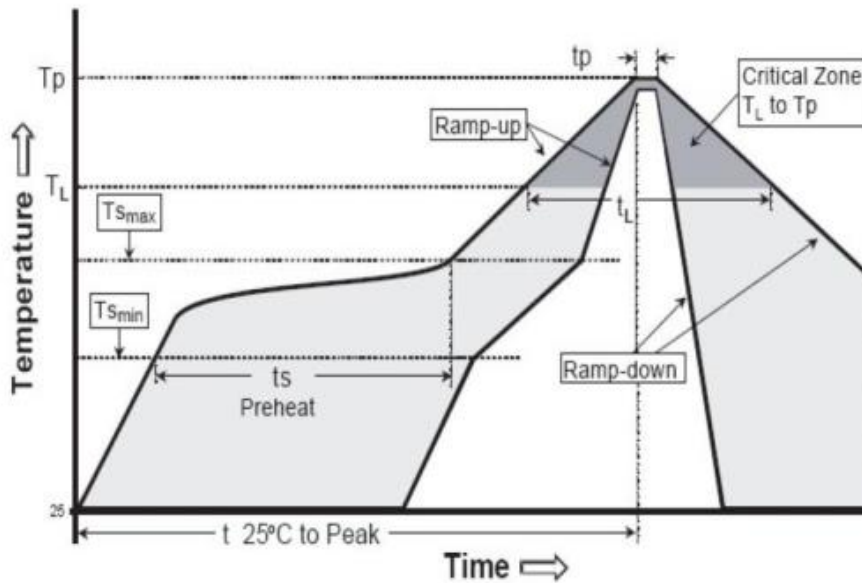

Profile Features	Lead-free solder	Lead solder	Soldering by Manual
Ramp-up Speed(Ts max to Tp)	3 °C/ second max.	3 °C/ second max.	Max. temperature: 350°C 3 seconds/1 time
Preheat: Min. Temperature(Tsmin)	150 °C	100 °C	
Preheat: Max.Temperature(Tsmax)	200 °C	150 °C	
Preheat: Time (tsmin to tsmax)	60~180 seconds	60~120 seconds	
Temperature to Keep: (TL)	217 °C	183 °C	
Time to Keep: (tL)	60~150 seconds	60~150 seconds	
Peak Temperature (Tp)	260 °C	215 °C	
Time within the peak temperature (tp)	20~40 seconds	10~30 seconds	
Ramp-down Speed	6°C/ second max.	6°C/ second max.	
Time to the peak Temperature	8 minutes max.	6 minutes max.	

DIMENSIONS

Unit: mm

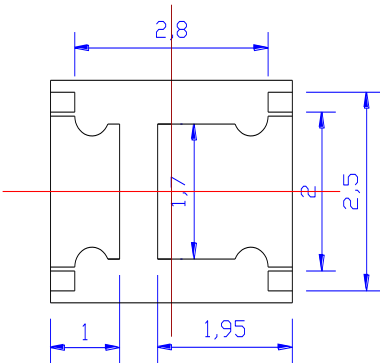
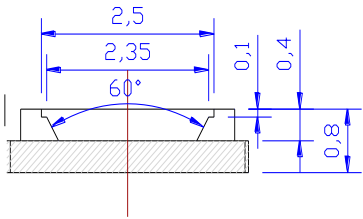
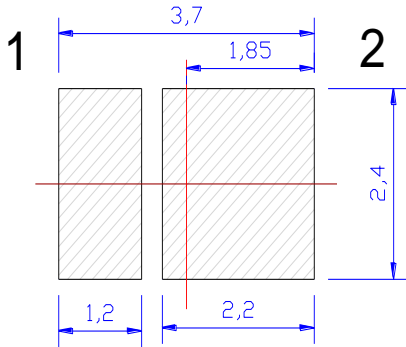
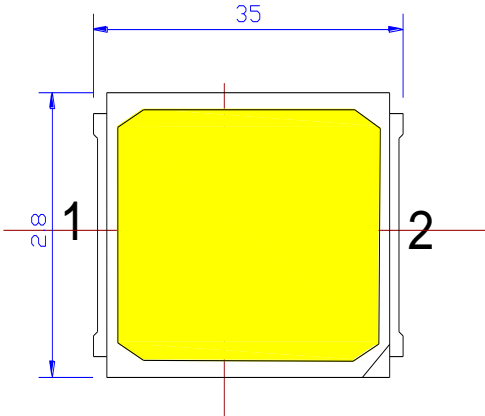

Notes :

*All dimensions are in millimeters.(tolerance:±0.2mm)

*The appearance and specifications of the product may be changed for improvement without notice.

PACKAGING

Tape Specifications (Units : mm)

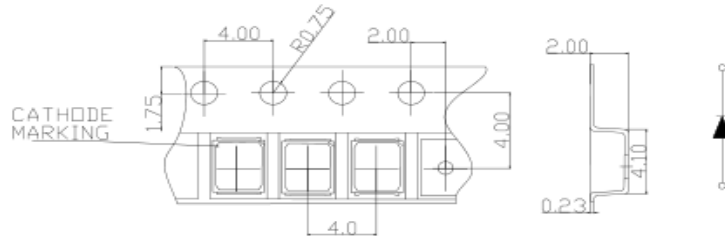

Reel Dimensions

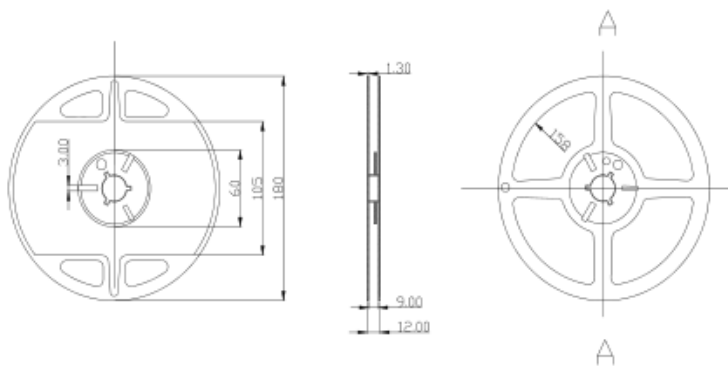

Moisture Resistant Packaging



PRECAUTIONS

Storage

1. Moisture proof and anti-electrostatic package with moisture absorbent material is used, to keep moisture to a minimum.
2. Before opening the package, the product should be kept at 30°C or less and humidity less than 60% RH, and be used within a year.
3. After opening the package, the product should be stored at 30°C or less and humidity less than 10%RH, and be soldered within 24 hrs (1day). It is recommended that the product be operated at the workshop condition of 30°C or less and humidity less than 60%RH.
4. If the moisture absorbent material has faded away or the LEDs have exceeded the storage time, baking treatment should be performed based on the following condition: (80±5)°C for 24 hours.

Static Electricity

1. Static electricity or surge voltage damages the LEDs. Damaged LEDs will show some unusual characteristics such as the forward voltage becomes lower, or the LEDs do not light at the low current, even not light.
2. All devices, equipment and machinery must be properly grounded. At the same time, it is recommended that wrist bands or anti-electrostatic gloves, anti-electrostatic containers be used when dealing with the LEDs.

Vulcanization

LED curing is due to sulfur being in bracket and the +1 price of silver in the chemical reaction generated Ag₂S in the process. It will lead to the capacity of reflecting of silver layer reducing, light color temperature drift and serious decline, seriously affecting the performance of the product. So we should take corresponding measures to avoid vulcanization, such as to avoid using sulphur volatile substances and keeping away from high sulphur content of the material.

Design Consideration

1. In designing a circuit, the current through each LED must not exceed the absolute maximum rating specified for each LED. In the meanwhile, resistors for protection should be applied, otherwise slight voltage shift will cause big current change, burn out may happen.
2. It is recommended to use Circuit A which regulates the current flowing through each LED rather than Circuit B. When driving LEDs with a constant voltage in Circuit B, the current through the LEDs may vary due to the variation in Forward Voltage (VF) of the LEDs. In the worst case, some LED may be subjected to stresses in excess of the Absolute Maximum Rating.

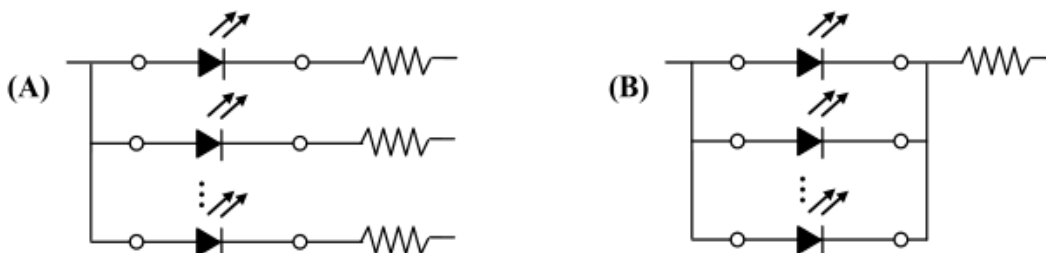

3. Thermal Design is paramount importance because heat generation may result in the Characteristics decline, such as brightness decreased, Color changed and so on. Please consider the heat generation of the LEDs when making the system design.

PRECAUTIONS

Safety Advice For Human Eyes

Viewing direct to the light emitting center of the LEDs, especially those of great Luminous Intensity will cause great hazard to human eyes. Please be careful.

The safe temperature for LEDs working

The high temperature will make the LEDs' Luminous Intensity decreased radically, if LEDs worked in hoteyes. Please be careful. environment for a long time, they will be disabled easily. When LEDs are working in a closed array, we suggest that the LEDs' surface temperature should be lower than 55°C and the legs' temperature should be lower than 75°C.

Others

1. When handling the product, touching the encapsulant with bare hands will not only contaminate its surface, but also affect on its optical characteristics. Excessive force to the encapsulant might result in catastrophic failure of the LEDs due to Die breakage or wire deformation. For this reason, please do not put excessive stress on LEDs, especially when the LEDs are heated such as during Reflow Soldering.



2. The epoxy resin of encapsulant is fragile, so please avoid scratch or friction over the epoxy resin surface. While handling the product with tweezers, do not hold by the epoxy resin, be careful.