

0.2W 2835 RED LED Datasheet

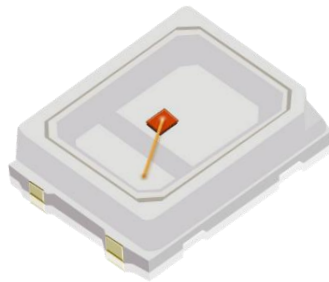

Features:

- Slim Size SMD Package: Design Flexibility
- High Lumen Output and High Radiant Flux
- Stable Performance & Great CCT Unity
- R, G, B, Y, A, UV, IR Light Color Available
- Full Wavelength 365-850nm Available
- Environmental Friendly; ROHS Compliance
- Customized Service Available

Applications:

- LED Module, Illuminated Advertising
- Tube Light, Panel Light, Ceiling Lamp and other LED Indoor Lights
- Flood Light, High Bay Light, Tunnel Light and other LED Outdoor Lights
- LED Aquarium Light, LED Plant Growing Light..

TABLE OF CONTENTS

PRODUCT NAMING RULES-----3

CHARACTERISTICS-----4

CHARACTERISTIC CURVES-----5

CHARACTERISTIC CURVES-----6

RELIABILITY TESTS-----7

SOLDERING CONDITIONS-----8

DIMENSION-----9

PACKAGING-----10

PRECAUTIONS-----11

PRECAUTIONS-----12

PRODUCT NAMING RULES

LKL	XXXX	XX	X	X	XXX
LKL	Type	Light Color	Chip QTY	Beam Angle	Brightness
lekoled	2835	V1: 360-370nm	1: 1EA	0: 120°/140°	02: 2-3LM
		V2: 370-380nm	2: 2EA		04: 4-5LM
		V3: 380-390nm	3: 3EA		05: 5-6LM
		V4: 390-400nm		10: 10-12LM
		V5: 400-410nm			18: 18-20LM
		V6: 410-420nm		
		RB: 440-450nm			
		B2: 450-460nm			
		B3: 460-470nm			
		G2: 520-530nm			
		Y4: 585-595nm			
		A6: 600-610nm			
		R1: 620-630nm			
		DR: 660-665nm			
		IR1: 730-740nm			
		IR3: 850nm			
				

CHARACTERISTICS

Light Color	Wavelength (nm)	2.0-2.6V @60mA	Model No.
		Luminous Flux	
RED	620-625	7-8LM	LKL-2835R11007

Absolute Maximum Ratings at Tj=25°C			
Parameters	Symbol	Value	Unit
Forward Current	I _F	60	mA
Peak Pulsed Forward Current	I _{FP}	80	mA
Power Dissipation	P _D	0,5	W
Reverse Voltage	V _R	5	V
Viewing Angle	2θ 1/2	120	Deg
Operating Temperature	T _{OPR}	-40 ~ +60	°C
Storage Temperature	T _{STG}	-40 ~ +85	°C
Junction Temperature	T _J	115	°C
Soldering Temperature	T _{SLD}	Reflow Soldering: 230°C or 260°C for 10Sec	

Electrical/ Optical Characteristics at Tj=25°C						
Parameters	Symbol	Min	Type	Max	Unit	Condition
Forward Voltage	V _F	2.0	--	2.6	V	IF=60mA
Reverse Current	I _R		10		μA	VR=5V
Radiant Flux	Φ _e	7		8	LM	IF=60mA
Wavelength	λ _p	620		625	nm	IF=60mA
Thermal Resistance	R _{th j-sp}		8		°C/W	IF=60mA
Electrostatic Discharge	ESD	2000			V	HBM

RELATIVE SPECTRAL POWER DISTRIBUTION

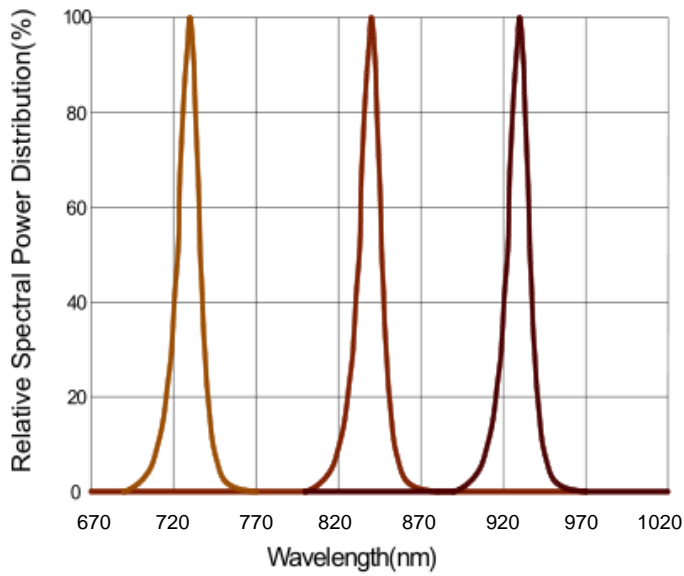
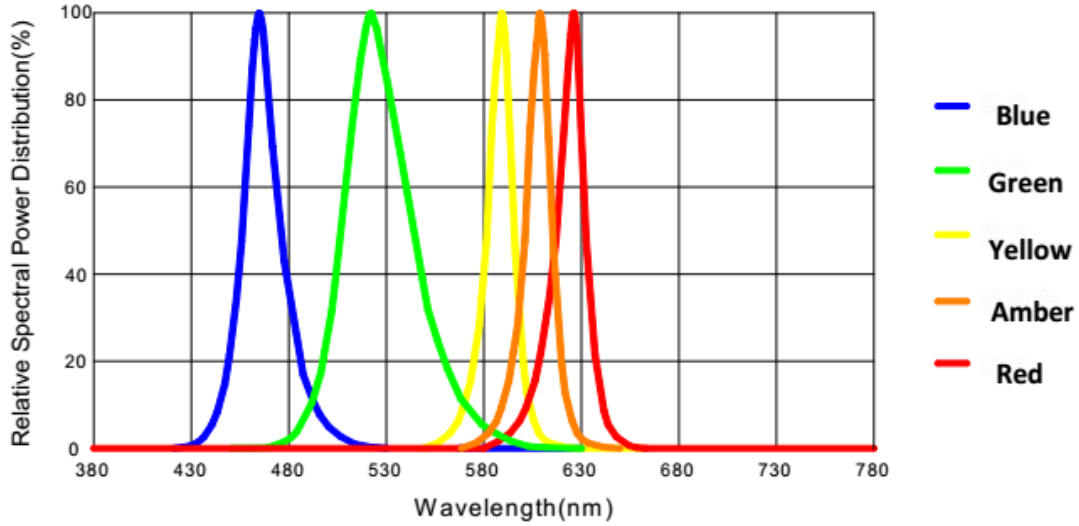

TYPICAL CHARACTERISTIC CURVES

Specifications (IF=60mA, Tc=25°C)

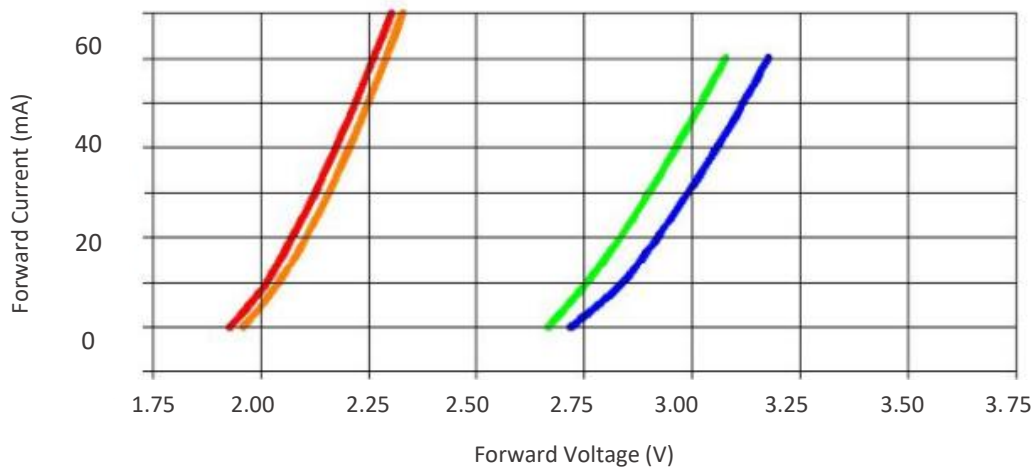
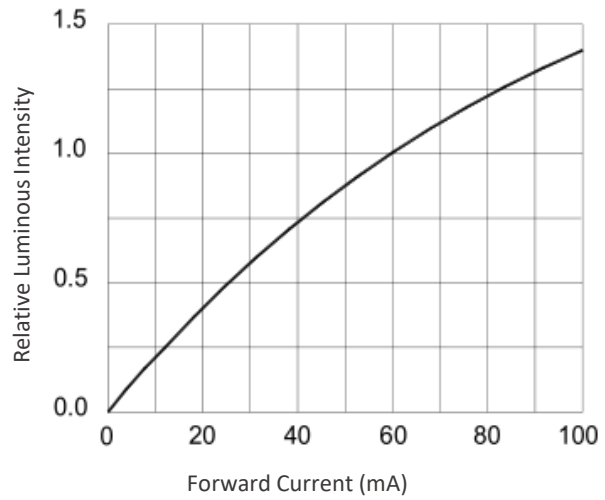
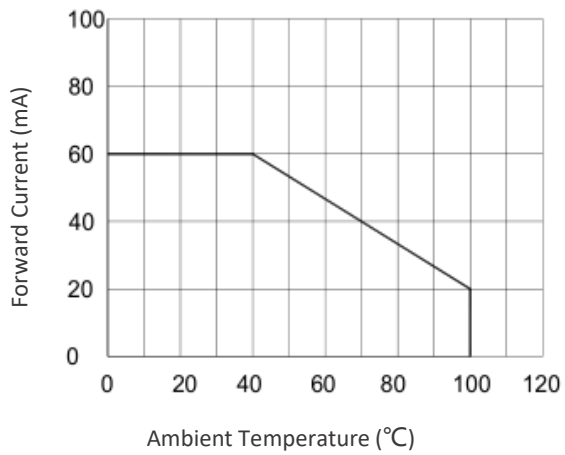

RELIABILITY TESTS

Test Items	Test Conditions	Sample QTY	Ac/Re
Aging Test	IF=60mA, Ta=25°C x6000hrs	22	0/1
	IF=60mA, Ta=85°C x6000hrs	22	0/1
High Temperature Storage	100°C x1000hrs	22	0/1
Low Temperature Storage	-40°C x1000hrs	22	0/1
High Temp & Humidity	IF=60-150mA, 85°C, 85% RH for 6000hrs	22	0/1
Temperature Shock	-40°Cx30 min & +100°Cx30 min, 100cycle	22	0/1
ESD(HBM)	2000V HBM/ 1 Time	10	0/1

Criteria for Judging LED Failure (Tc= 25°C)

Items	Symbol	Test Conditions	Criteria for Judging LED Failure
Forward Voltage	VF	IF=60mA	>U x 1.1
Reverse Current	IR	VR=5V	IR>/= 10μA
Lumen	ΦV	IF=60mA	<S x 0.7

U refers to max value; S refers to initial value.

Notes: Judging criteria based on Tc=25°C.

TYPICAL CHARACTERISTIC CURVES

REFLOW SOLDERING PROFILE

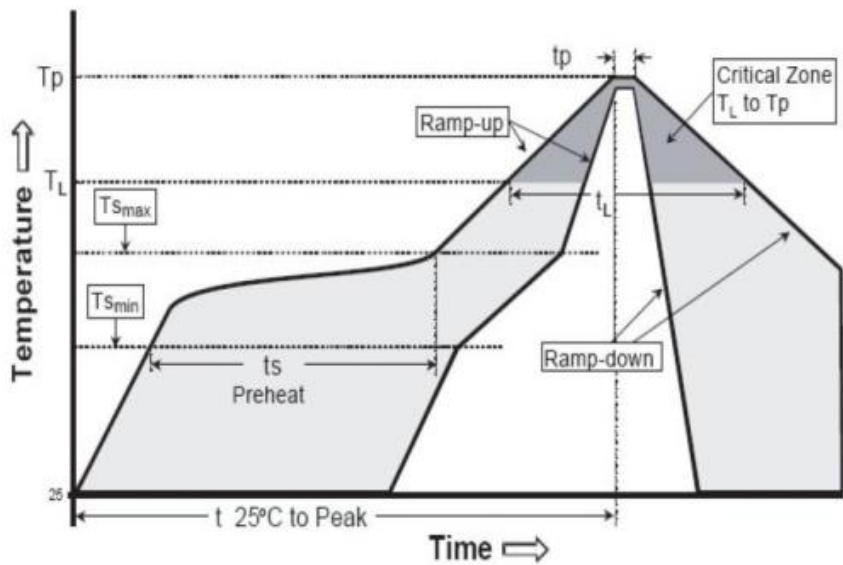

Profile Features	Lead-free solder	Lead solder	Soldering by Manual
Ramp-up Speed(Ts max to Tp)	3 °C/ second max.	3 °C/ second max.	Max. temperature: 350°C 3 seconds/1 time
Preheat: Min. Temperature(Tsmin)	150 °C	100 °C	
Preheat: Max. Temperature(Tsmax)	200 °C	150 °C	
Preheat: Time (tsmin to tsmax)	60~180 seconds	60~120 seconds	
Temperature to Keep: (Tl)	217 °C	183 °C	
Time to Keep: (tl)	60~150 seconds	60~150 seconds	
Peak Temperature (Tp)	260 °C	215 °C	
Time within the peak temperature (tp)	20~40 seconds	10~30 seconds	
Ramp-down Speed	6°C/ second max.	6°C/ second max.	
Time to the peak Temperature	8 minutes max.	6 minutes max.	

DIMENSIONS

Unit: mm

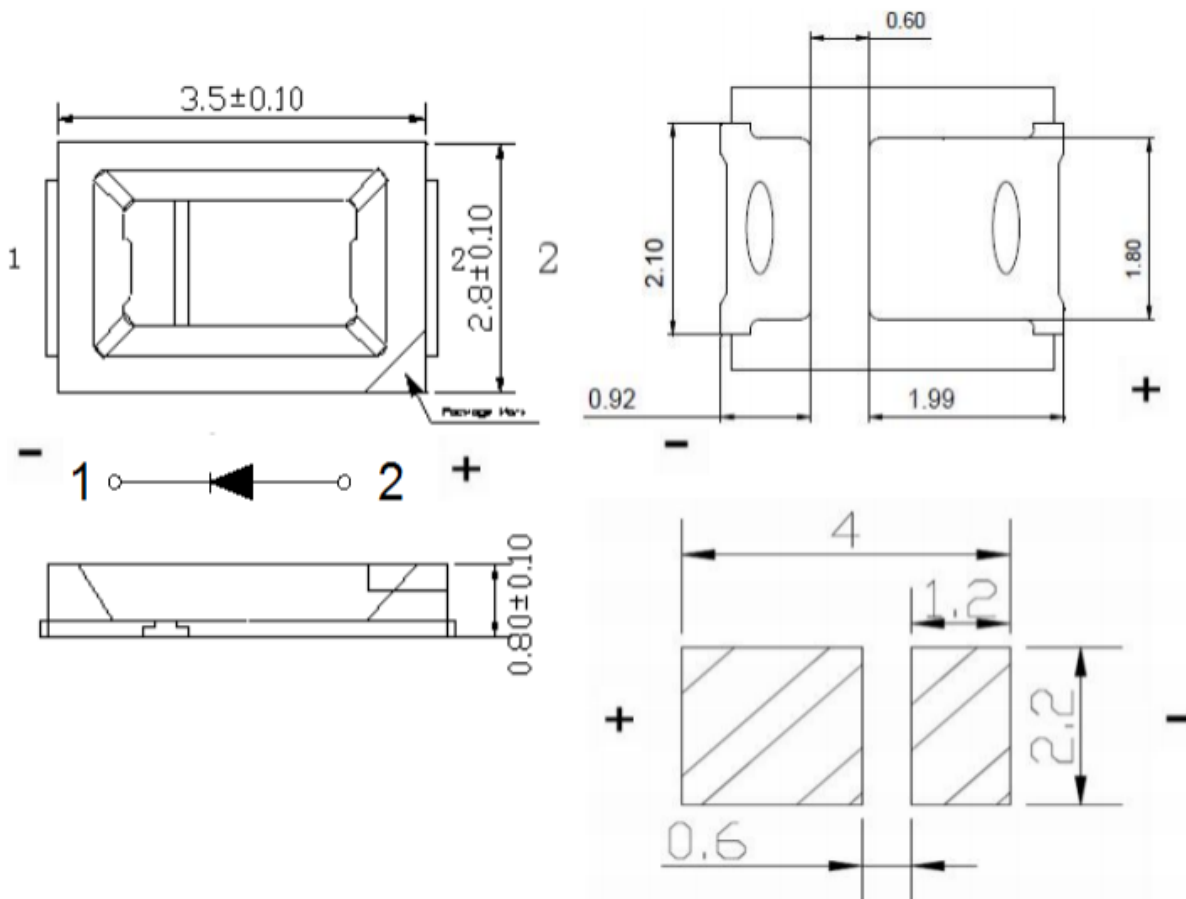

Notes :

*All dimensions are in millimeters.(tolerance: ± 0.2 mm)

*The mark is anode.

*The appearance and specifications of the product may be changed for improvement without notice.

PACKAGING

Tape Specifications (Units : mm)

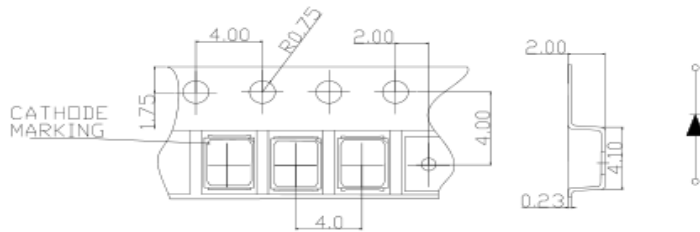

Reel Dimensions

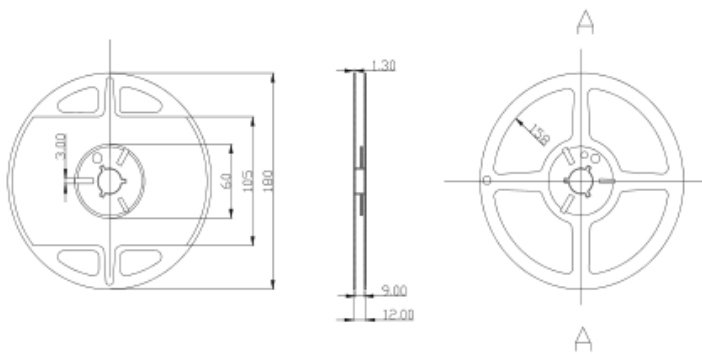

Moisture Resistant Packaging

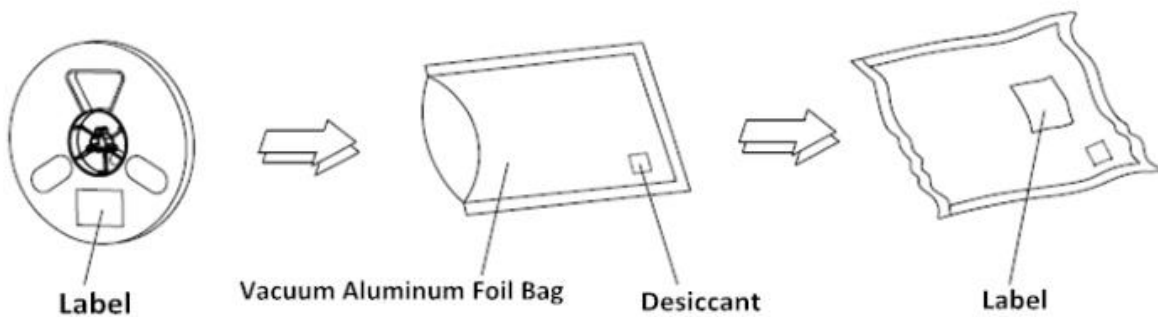

PRECAUTIONS

Storage

1. Moisture proof and anti-electrostatic package with moisture absorbent material is used, to keep moisture to a minimum.
2. Before opening the package, the product should be kept at 30°C or less and humidity less than 60% RH, and be used within a year.
3. After opening the package, the product should be stored at 30°C or less and humidity less than 10%RH, and be soldered within 24 hrs (1day). It is recommended that the product be operated at the workshop condition of 30°C or less and humidity less than 60%RH.
4. If the moisture absorbent material has faded away or the LEDs have exceeded the storage time, baking treatment should be performed based on the following condition: (80±5)°C for 24 hours.

Static Electricity

1. Static electricity or surge voltage damages the LEDs. Damaged LEDs will show some unusual characteristics such as the forward voltage becomes lower, or the LEDs do not light at the low current, even not light.
2. All devices, equipment and machinery must be properly grounded. At the same time, it is recommended that wrist bands or anti-electrostatic gloves, anti-electrostatic containers be used when dealing with the LEDs.

Vulcanization

LED curing is due to sulfur being in bracket and the +1 price of silver in the chemical reaction generated Ag₂S in the process. It will lead to the capacity of reflecting of silver layer reducing, light color temperature drift and serious decline, seriously affecting the performance of the product. So we should take corresponding measures to avoid vulcanization, such as to avoid using sulphur volatile substances and keeping away from high sulphur content of the material.

Design Consideration

1. In designing a circuit, the current through each LED must not exceed the absolute maximum rating specified for each LED. In the meanwhile, resistors for protection should be applied, otherwise slight voltage shift will cause big current change, burn out may happen.
2. It is recommended to use Circuit A which regulates the current flowing through each LED rather than Circuit B. When driving LEDs with a constant voltage in Circuit B, the current through the LEDs may vary due to the variation in Forward Voltage (VF) of the LEDs. In the worst case, some LED may be subjected to stresses in excess of the Absolute Maximum Rating.

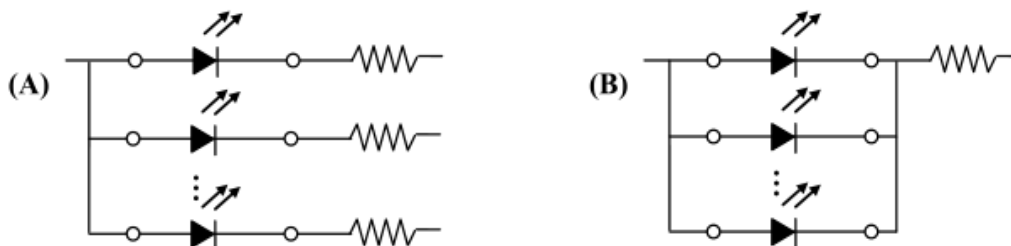

3. Thermal Design is paramount importance because heat generation may result in the characteristics decline, such as brightness decreased, Color changed and so on. Please consider the heat generation of the LEDs when making the system design.

PRECAUTIONS

Safety Advice For Human Eyes

Viewing direct to the light emitting center of the LEDs, especially those of great Luminous Intensity will cause great hazard to human eyes. Please be careful.

The safe temperature for LEDs working

The high temperature will make the LEDs' Luminous Intensity decreased radically, if LEDs worked in hoteyes. Please be careful. environment for a long time, they will be disabled easily. When LEDs are working in a closed array, we suggest that the LEDs' surface temperature should be lower than 55°C and the legs' temperature should be lower than 75°C.

Others

1. When handling the product, touching the encapsulant with bare hands will not only contaminate its surface, but also affect on its optical characteristics. Excessive force to the encapsulant might result in catastrophic failure of the LEDs due to Die breakage or wire deformation. For this reason, please do not put excessive stress on LEDs, especially when the LEDs are heated such as during Reflow Soldering.

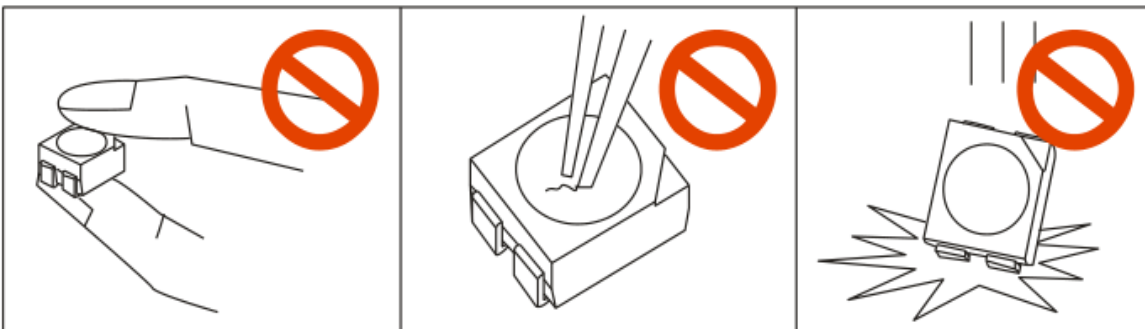

2. The epoxy resin of encapsulant is fragile, so please avoid scratch or friction over the epoxy resin surface. While handling the product with tweezers, do not hold by the epoxy resin, be careful.

